

Intel® Pineview D525 Mini-ITX Industrial MB, 12V DC-in

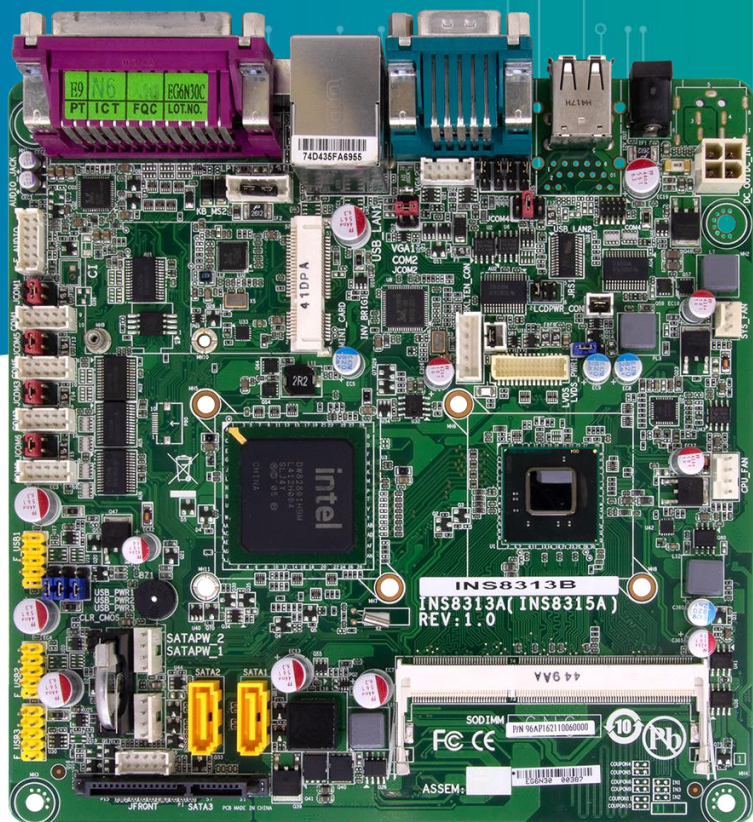

FEATURE

- Support Intel® Pineview D525 CPU onboard
- VGA/LVDS Dual display
- Mini PCIe slot
- 9 x USB ports
- 6 x COM with 5V/12V selection
- 1 x RJ11 supports Cash Drawer
- 12V DC-in & 12V DC-out

Specifications

SYSTEM

COM Type	Intel® Atom™ D525 1.8GHz onboard
Chipset	Intel® ICH8M
Memory Type	1 x 204-pin SO-DIMM DDR3 800/1066 up to 4GB
BIOS	AMI® BIOS
Super I/O	ITE ITE87821
2nd Super I/O	Fintek F81214R
Watchdog	1-255 sec. or 1-255 min. software programmable and can be generate system reset
Expansion Slot	1 x Mini PCIe slot

DISPLAY

Chipset	Integrated Intel® GMA3150 GFX Render Core
Onboard VGA	Yes (Max resolution 2048x1536)
LVDS	Support single channel 18 bit LVDS (Max.resolution 1366 x 768)
Dual Independent Displays Capability	VGA + LVDS

AUDIO

Codec	Realtek ALC269 High Definition Audio Codec
-------	--------------------------------------------

ETHERNET

Chipset	1 x RTL 8111E GbE LAN
WOL	Yes
Boot from LAN	Yes for PXE

REAR I/O

Ethernet	Dual Gigabit (10/100/1000) Ports
----------	----------------------------------

INTERFACE

VGA	1
Ethernet	1 x RJ45
Audio	1 x Speaker-out

USB 1.1/2.0	4
PS/2	1
RJ11	1 supports Cash Drawer
LPT	1

INTERNAL I/O

SATA	3 x SATAII <ul style="list-style-type: none"> • 2 x 7 pin SATA II • 1 x 7 pin+15 pin SATAII
USB 1.1/2.0	9 x USB
LVDS	<ul style="list-style-type: none"> • 5 ports by 2x5 pin header-2.54 mm pitch • 4 ports on rear I/O
COM	6 x COM <ul style="list-style-type: none"> • COM1 port supports RS232 (0/5/12V) • COM2 port supports RS232/422/485 (0/5/12V) • COM3~COM6 ports supports RS232 (0/5/12V) • COM4 port supports VFD mode
LVDS	20 pin Hirose DF13
Fan	CPU/System fan connector

MECHANICAL AND ENVIRONMENT

Form Factor	Mini-ITX
Power Type	+12V DC-in, AT/ATX modesupport
Dimensions	170 x 170mm (6.69" x 6.69")
Operating Temperature	0 to 60 °C
Storage Temperature	-20 to 85°C
Relative Humidity	10% ~ 90%, non-condensing

Block Diagram

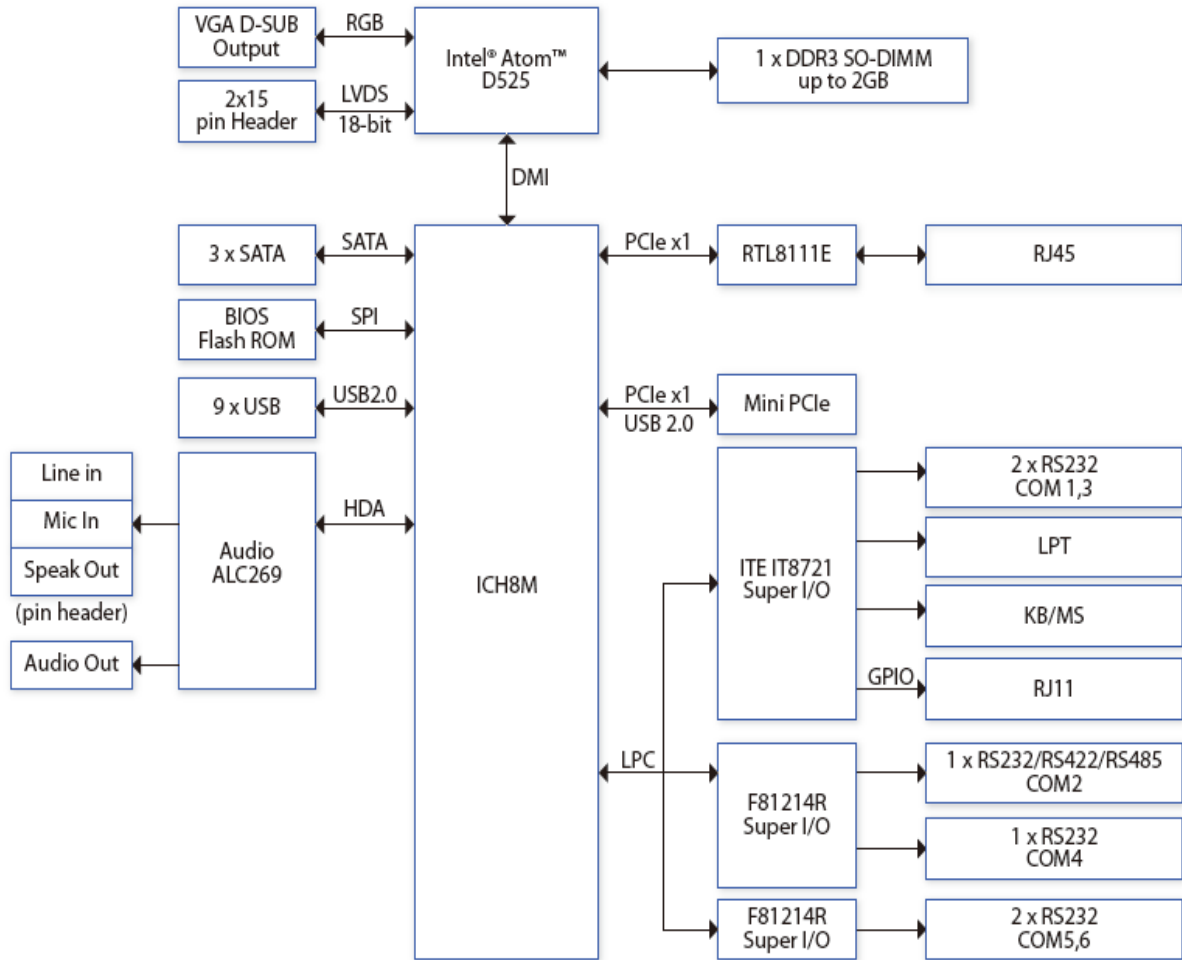

Board Placement

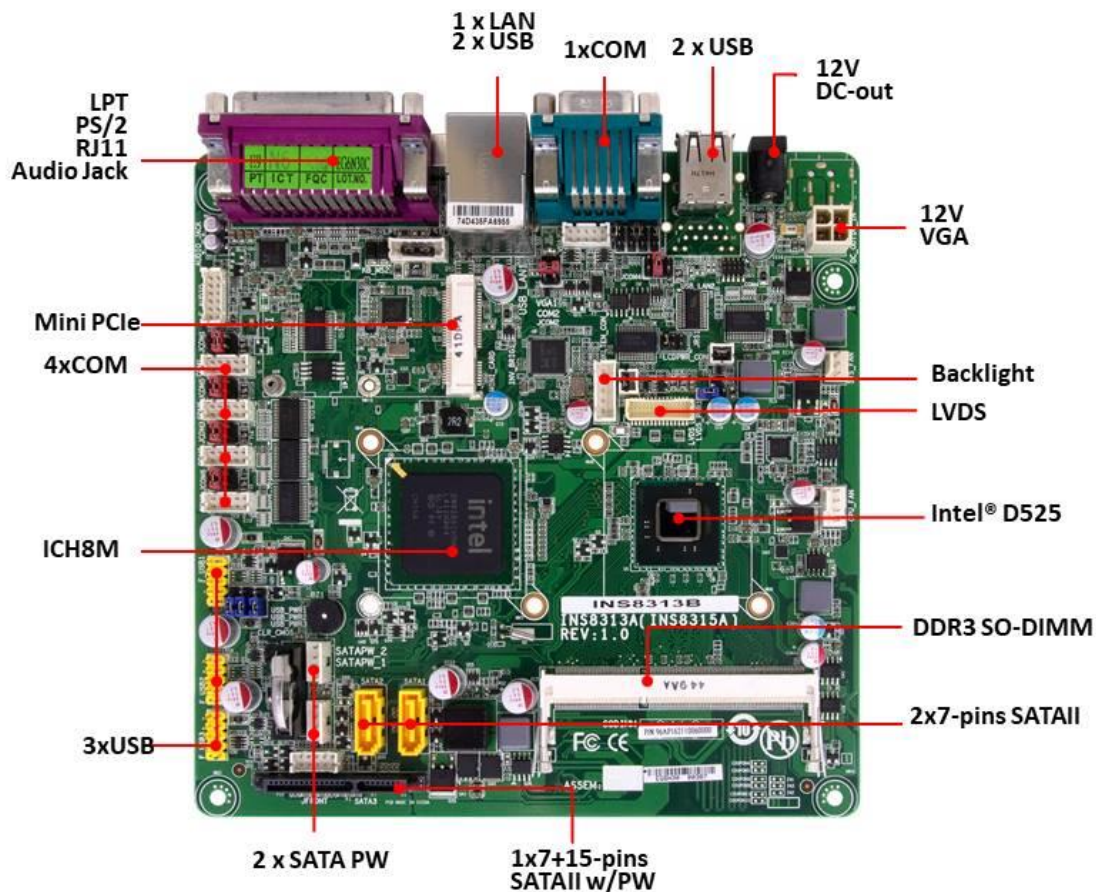

Ordering Information

MODULES

Model Number	Description
INS8313B	Mini-ITX Industrial Motherboard Intel® Pineview D525 with DDR3 SO-DIMM, Dual Display by VGA/LVDS, Single GbE LAN, Audio, 6 x COM, 9 x USB and +12V DC-in