

# OXY5740A

Intel® QM175 EBX SBC, Kabylake  
i7-7820EQ (4C x 3.7/3.0 GHz), 8M Cache,  
with SSD Soldering Onboard, Stackable  
with StackPC & FPE Expansio

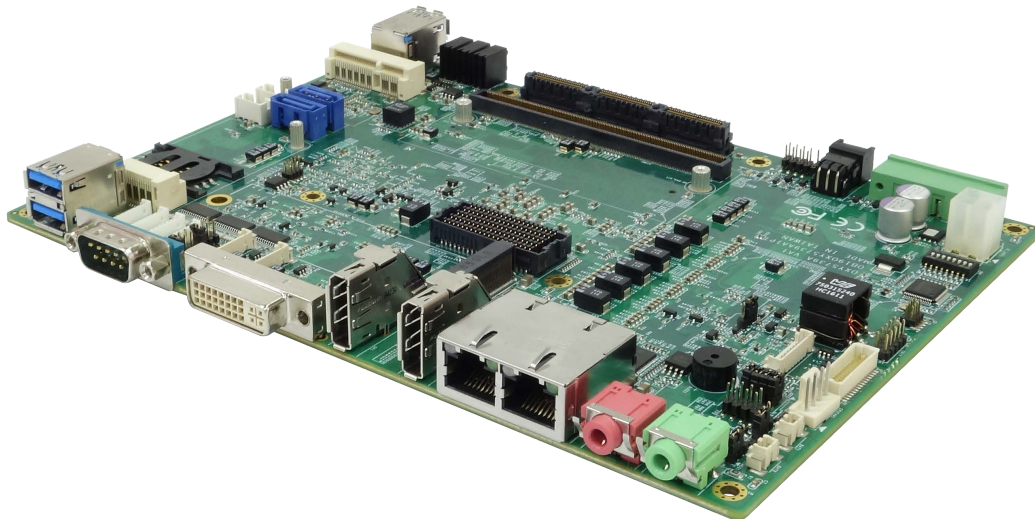

## **Safety Information**

### **1. Electrical safety**

- To prevent electrical shock hazard, disconnect the power cable from the electrical outlet before relocating the system.
- When adding or removing devices to or from the system, ensure that the power cables for the devices are unplugged before the signal cables are connected. If possible, disconnect all power cables from the existing system before you add a device.
- Before connecting or removing signal cables from the motherboard, ensure that all power cables are unplugged.
- Seek professional assistance before using an adapter or extension cord. These devices could interrupt the grounding circuit.
- Make sure that your power supply is set to the correct voltage in your area.
- If you are not sure about the voltage of the electrical outlet you are using, contact your local power company.
- If the power supply is broken, do not try to fix it by yourself. Contact a qualified service technician or your local distributor.

### **2. Operation safety**

- Before installing the motherboard and adding devices on it, carefully read all the manuals that came with the package.
- Before using the product, make sure all cables are correctly connected and the power cables are not damaged. If you detect any damage, contact your dealer immediately.
- To avoid short circuits, keep paper clips, screws, and staples away from connectors, slots, sockets and circuitry.
- Avoid dust, humidity, and temperature extremes. Do not place the product in any area where it may become wet.
- Place the product on a stable surface.
- If you encounter any technical problems with the product, contact your local distributor

### **Statement**

- All rights reserved. No part of this publication may be reproduced in any form or by any means, without prior written permission from the publisher.
- All trademarks are the properties of the respective owners.
- All product specifications are subject to change without prior notice

## Revision History

Revision	Date(dd/mm/yyyy)	Changes
Version 1.0	11/11/2019	Initial release

### Packing list:

- OXY5740A EBX
- CD (Driver + user's manual)

### Optional Accessories:

- 1 x Terminal block
- [Optional] Cable kit for OXY5740A: 1 x SATA, 1 x SATA power, 2 x COM



**If any of the above items is damaged or missing, please contact your local distributor.**

# Table of Contents

## Chapter 1: Product Information

Safety Information .....	1
1. Electrical safety .....	1
2. Operation safety .....	1
Statement .....	1
Revision History .....	2
Packing list: .....	2
Optional Accessories: .....	2
Table of Contents .....	3-4
Chapter 1: Product Information .....	5
1.1 Block Diagram .....	5
1.2 Key Features .....	6
1.3 Board Placement .....	8
Chapter 2: Jumpers and Connectors .....	9
2.1 Jumpers and connectors list .....	9
2.2 Jumper Settings .....	10
CN19: LVDS CONNECTOR .....	10
SW3: LVDS Resolution select .....	10
JP3: LVDS_VDD select .....	12
CN18: Inverter connector .....	12
CPU FAN: CPU FAN Connector .....	13
CN1/CN3: Serial ATA Connectors .....	11
CN2/CN4: SATA POWER Connectors .....	11
CN17: Digital I/O Box Head .....	11
JP14: MCARD1 mSATA and mPCIe selection .....	12
MCARD1: Mini PCIe Card Slot<COLAY M SATA> .....	132
MCARD2: Mini PCIe Card Slot .....	13
LAN1/LAN2 .....	13
CN20: USB 2.0 .....	14
CN21: USB 2.0 .....	14
CN8: USB3.0 *2 .....	14
CN9: USB3.0 *2 .....	14
CN6: Audio Jacks Connector (MIC) .....	15
CN7: Audio Jacks Connector (Line-Out) .....	15
CN22: DC Adapter Power Input .....	115
DC_JACK1: DC-IN .....	15

CN10: LPC (Update BIOS) .....	15
DP1: DISPLAY PORT .....	15
DP2: DISPLAY PORT .....	156
SIM_CARD1: SIM card socket .....	156
DVI: DVI-D .....	16
COM1: RS232/422/485 with 5V/12V selectable .....	16
JP4: COM1 5V/12V selection .....	16
JP5: COM2 5V/12V selection .....	16
COM2: RS232 .....	17
COM3/4: RS232 .....	17
CON A1: CONNECTOR A TOP .....	18
FPE1: StackPC FPE Top Connector: .....	19
LED1: LAN1 LED STATUS .....	20
LED2: LAN2 LED STATUS .....	20
LED3: POWER/HDD LED .....	20
SW1: POWER BUTTON .....	20
FP1: Front Panel .....	20
FP2: LAN LED .....	21
Chapter 3: Getting Started .....	22
3.1 Installing System Memory .....	23
<b>CHAPTER 4: AMI BIOS UTILITY .....</b>	<b>25</b>
4.1 STARTING .....	25
4.2 NAVIGATION KEYS .....	25
4.3 MAIN PAGE .....	26
4.4 ADVANCED PAGE .....	26
4.4.1 CPU Configuration .....	27
4.4.2 Power & Performance .....	27
4.4.3 PCH-FW Configuration .....	28
4.4.4 ACPI Setting .....	28
4.4.5 IT8786 Super IO Configuration .....	29
4.4.6 Hardware Monitor .....	31
4.4.7 CSM Configuration .....	32
4.5 Chipset .....	32
4.5.1 SA Configuration .....	33
4.5.1.1 Graphics Configuration .....	33
4.5.1.2 LCD Control .....	34
4.5.2 PCH-IO Configuration .....	35
4.6 Security .....	35
4.7 Boot .....	35
4.8 Save & Exit .....	36

# Chapter 1: Product Information

## 1.1 Block Diagram

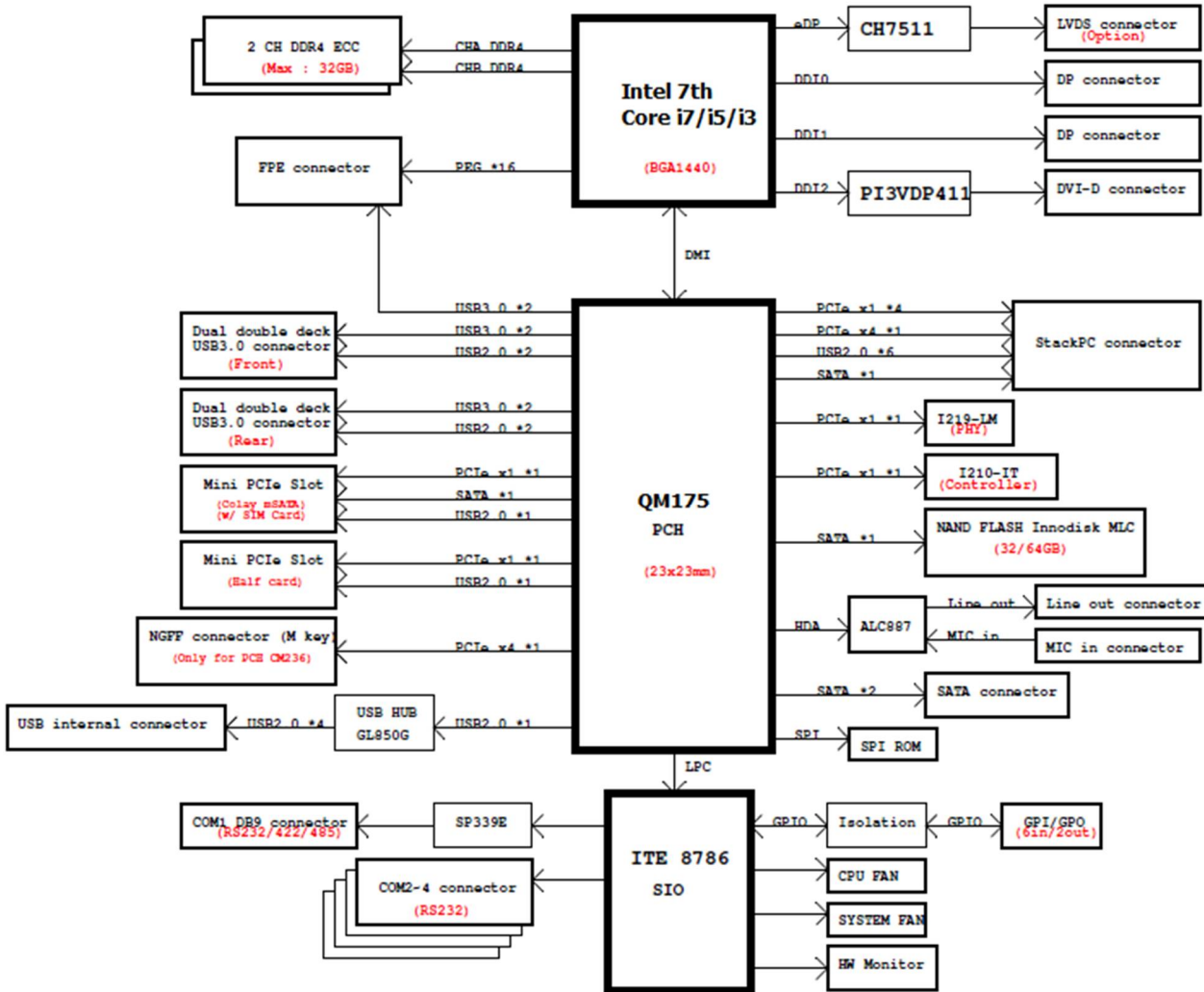

## 1.2 Key Features

System	
CPU Type	Intel® KabyLake-H Core™ i7/i5, BGA type Intel® Core™ i7-7820EQ (8M Cache, up to 3.70 GHz) Intel® Core™ i5-7440EQ (6M Cache, up to 3.60 GHz)
Chipset	Intel® Haswell QM175 PCH
Memory Type	1 x DDR4 XR-DIMM up to 16GB SDRAM 1 x DDR4 SO-DIMM up to 16GB SDRAM Max. Capacity 32GB
BIOS	AMI® UEFI BIOS
Supoer I/O	ITE8786
Watchdog	1-255 sec. or 1-255 min. software programmable can generate system reset
Expansion Slot	1 x Full-size mPCIe/mSATA and SIM 1 x Half-size mPCIe
Display	
Chipset	Intel® HD Graphics 630
DisplayPort	2, Max resolution up to 3840 x 2160
DVI-D	1, Max resolution up to 2048 x 1536
LVDS	Dual channel 24-bit LVDS
Audio	
Codec	Realtek ALC887 High Definition Audio Codec
Ethernet	
Chipset	Intel® I210IT & i219-LM GbE
WOL	Yes
Boot from LAN	Yes for PXE
Rear I/O	
DisplayPort	1
DVI-D	1
Ethernet	2 x RJ45
COM Port	1 x RS232/422/485 with 5V/12V selectable
USB	2 x USB 3.0
Audio	1 x MIC, 1 x Line out
Front I/O	
USB	2 x USB 3.0
Indicator LED	LAN1, LAN2, Power, HDD LED
Power Button	1
Power Connector	1 (Terminal Block)
Internal I/O	
Touch Panel	1 x 5-pin
Front Panel	1 x (2 x 5-pin)
Smart Fan	1 x CPU FAN
Power Connector	2 (1 x 4-pin/ 2 x 2-pin)
SATA	2 x SATAIII (6 Gb/s)
USB	4 x USB 2.0

COM	3 x RS232 (COM2 with 5V/12V selectable)
LVDS	2 x 15-pin
DIO	2 x 10-pin, 6 in/2 out with isolation
FPE Connector	1
PCIe104 Connector	1
SIM card holder	1
<b>Power Requirements</b>	
Input Voltage	12 VDC (4-pin terminal block for V+, V+, V-, V-)
<b>Mechanical and Environment</b>	
Form Factor	EBX
Power Type	12V DC-in
Dimension	203 x 146 mm (5.75" x 8")
Operating Temp.	-40 to 85°C
Storage Temp.	-40 to 85°C
Relative Humidity	10% to 90%, non-condensing

**\*All specifications and photos are subject to change without notice.**



### 1.3 Board Placement

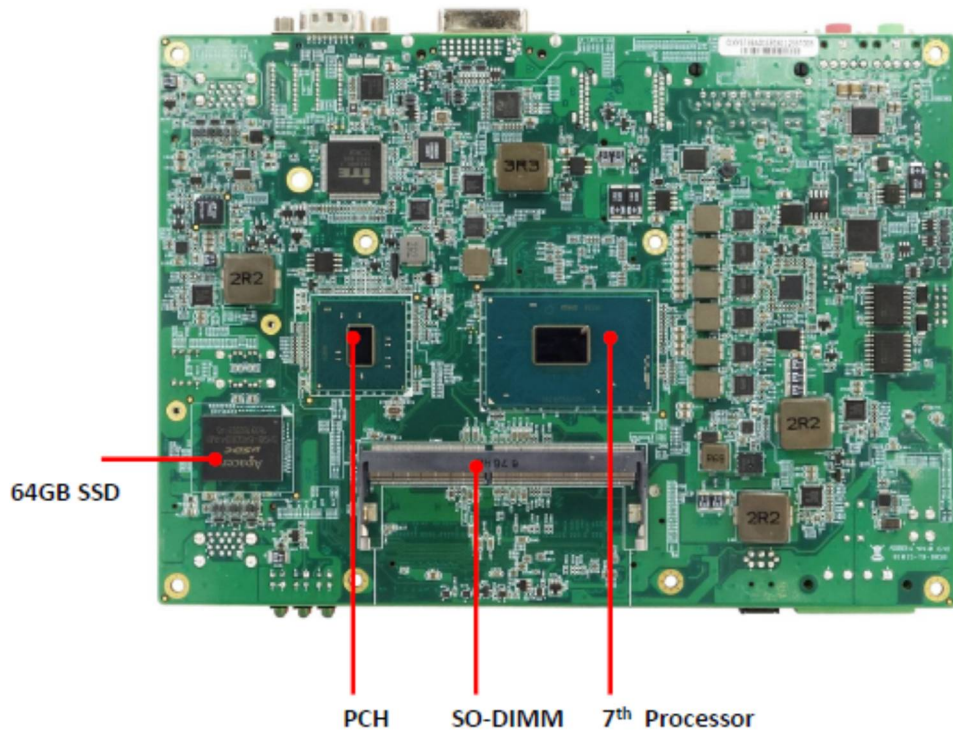
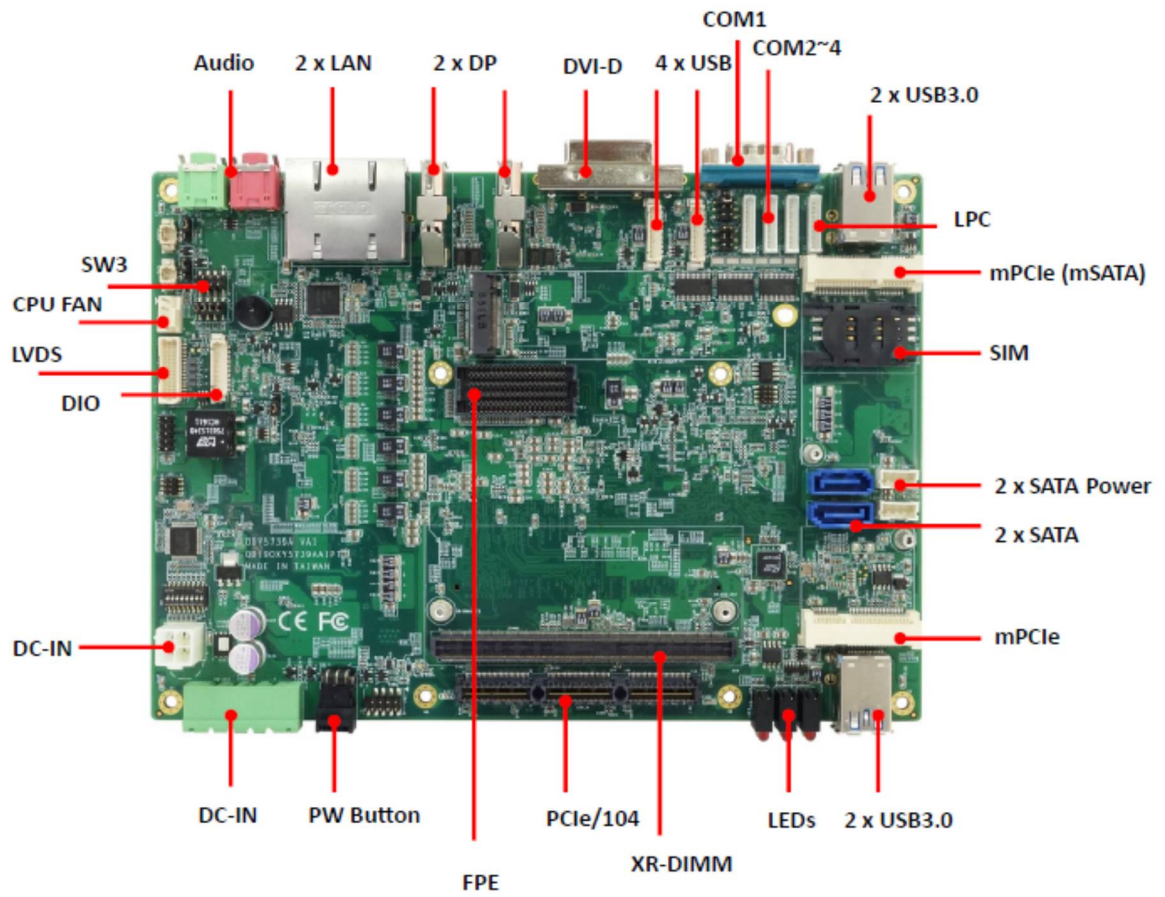

## Chapter 2: Jumpers and Connectors

### 2.1 Jumpers and connectors list

Label	Function
BAT1	BATTERY connector
DIMM0	DDR4 SO DIMM Socket
DIMM1	DDR4 XR DIMM Socket
CN19	LVDS CONNECTOR
MCARD1	Mini PCIE Card Slot<Full size Co-lay mSATA>
JP14	mSATA and mPCIE selection
MCARD2	Mini PCIE Card Slot (Half Size)
CN1/CN3	Serial ATA Connectors
CN2/CN4	SATA POWER
LAN1	INTEL I219LM
LAN2	INTEL I210IT
CN20/CN21	USB2.0 (Total 4 Port)
CN8	USB3.0 x 2
CN9	USB3.0 x 2
CN6	Audio Jacks Connector (MIC-In)
CN7	Audio Jacks Connector (Line-Out)
CN17	Digital I/O Box Head
CN10	LPC connector (Update BIOS)
DP1	DISPLAY PORT
DP2	DISPLAY PORT
DVI1	DVI-D
SIM_CARD1	SIM card socket
JP4	COM1 +12/+5V selection
JP5	COM2 +12/+5V selection
COM1	RS232/422/485 with 5V/12V selectable
COM2	RS232 with 5V/12V selectable
COM3	RS232
COM4	RS232
DC_JACK1	ATX12V DC connector
CN22	4P DC Terminal Block connector
CPU FAN	CPU FAN CONNECTOR
FPE1	StackPC FPE Top Connector
CON_A1	StackPC
LED1	LAN1 LED STATUS
LED2	LAN2 LED STATUS
LED3	POWER/HDD LED
SW1	POWER BUTTON
CN18	LVDS POWER BOX HEADER
SW3	LVDS Resolution selection
FP1	Front Panel
FP2	LAN LED

## 2.2 Jumper Settings

### CN19: LVDS CONNECTOR

PIN	DEFINITION	PIN	DEFINITION
1	LVDS_BCLK	2	GND
3	LVDS_BCLK#	4	LVDS_A3
5	GND	6	LVDS_A3#
7	LVDS_B3	8	GND
9	LVDS_B3#	10	LVDS_ACLK
11	LVDS_B2	12	LVDS_ACLK #
13	LVDS_B2#	14	GND
15	LVDS_B1	16	LVDS_A2
17	LVDS_B1#	18	LVDS_A2#
19	LVDS_B0	20	LVDS_A1
21	LVDS_B0#	22	LVDS_A1#
23	GND	24	LVDS_A0
25	LVDS_DCC_SC	26	LVDS_A0#
27	LVDS_DCC_SD	28	GND
29	LVDS_VDD (define by JP3)	30	LVDS_VDD (define by JP3)

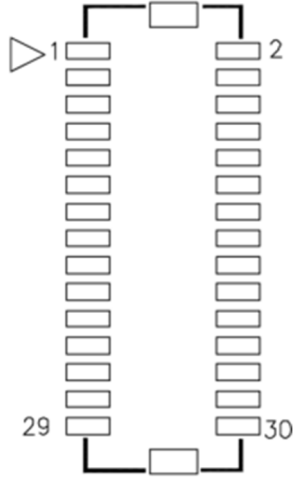

### SW3: LVDS Resolution select

SW3				
1	2	3	4	DEFINITION
on	on	on	on	800*600/18bit (single)
off	on	on	on	1024*768/18bit (single)
on	off	on	on	1024*768/24bit (single)
off	off	on	on	1280*800/18bit(single)
on	on	off	on	1280*1024/24bit (dual)
off	on	off	on	1366*768/24bit(single)
on	off	off	on	1440*900/24bit (dual)
off	off	off	on	1920*1080/24bit (dual)

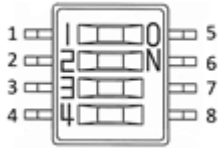

### JP3: LVDS\_VDD select

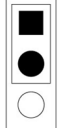
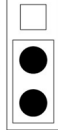
Jumper	Function description	Setting
1-2	3.3V	
2-3	5V	

Default setting: 2-3

**CN18: Inverter connector**

PIN	DEFINITION
1	12V
2	12V
3	12V
4	5VS
5	5VS
6	GND
7	GND
8	BL_EN
9	LVDS0_BKL_CTRL_R
10	GND

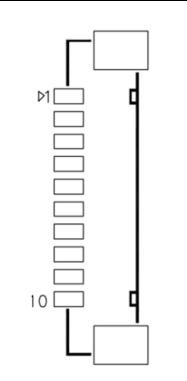

**CPU FAN: CPU FAN Connector**

PIN	DEFINITION
1	CPUFAN_PWN
2	CPUFAN_IO
3	CPUFAN_VCC
4	GND

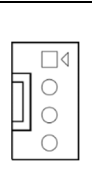

**CN1/CN3: Serial ATA Connectors**

PIN	DEFINITION
1	GND
2	TXP
3	TXN
4	GND
5	RXN
6	RXP
7	GND

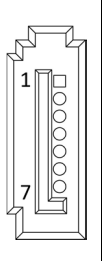

**CN2/CN4: SATA POWER Connector**

PIN	DEFINITION
1	12V
2	GND
3	GND
4	5VS

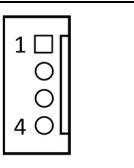

**CN17: Digital I/O Box Head**

PIN	DEFINITION	PIN	DEFINITION
1	VCC	2	GND
3	DI_0	4	DI_1
5	DI_2	6	DI_3
7	DI_4	8	DI_5
9	DO_0	10	DO_1

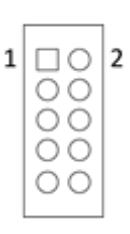

### JP14: MCARD1 mSATA and mPCIe selection

Jumper	Function description	Setting
1-2	mPCIe	
2-3	mSATA	

Default setting: 1-2

### MCARD1: Mini PCIE Card Slot<COLAY M SATA>

PIN	DEFINITION	PIN	DEFINITION
1	WAKE#	2	3.3VAUX
3	COEX1	4	GND
5	COEX2	6	1.5V
7	CLKREQ#	8	UIM_PWR
9	GND	10	UIM_DATA
11	REFCLK-	12	UIM_CLK
13	REFCLK+	14	UIM_RESET
15	GND	16	UIM_VPP
17	Reserved	18	GND
19	Reserved	20	W_Disable#
21	GND	22	PERST#
23	PERn0	24	+3.3Vaux
25	PERp0	26	GND
27	GND	28	1.5V
29	GND	30	SMB_CLK
31	PETn0	32	SMB_DATA
33	PETp0	34	GND
35	GND	36	USB_D-
37	GND	38	USB_D+
39	+3.3VAUX	40	GND
41	+3.3VAUX	42	LED_WWAN#
43	GND	44	LED_WLAN#
45	Reserved	46	LED_WPAN#
47	Reserved	48	1.5V
49	Reserved	50	GND
51	Reserved	52	3.3VAUX

### MCARD2: Mini PCIE Card Slot

PIN	DEFINITION	PIN	DEFINITION
1	WAKE#	2	3.3V
3	Reserved	4	GND
5	Reserved	6	1.5V
7	CLKREQ#	8	UIM_PWR
9	GND	10	UIM_DATA
11	REFCLK-	12	UIM_CLK
13	REFCLK+	14	UIM_RESET
15	GND	16	UIM_VPP
17	Reserved	18	GND
19	Reserved	20	W_Disable#
21	GND	22	PERST#
23	PERn0	24	3.3Vaux
25	PERp0	26	GND
27	GND	28	1.5V
29	GND	30	SMB_CLK
31	PETn0	32	SMB_DATA
33	PETp0	34	GND
35	GND	36	USB_D-
37	Reserved	38	USB_D+
39	Reserved	40	GND
41	Reserved	42	LED_WWAN#
43	Reserved	44	LED_WLAN#
45	Reserved	46	LED_WPAN#
47	Reserved	48	1.5V
49	Reserved	50	GND
51	Reserved	52	3.3V

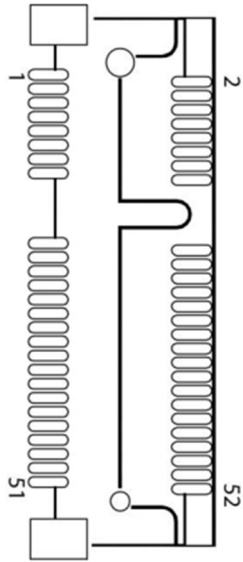

### LAN1: Intel I219LM

### LAN2: Intel I210IT

LAN1		LAN2	
PIN	DEFINITION	PIN	DEFINITION
A1	I218_LAN1_MDIO_DP	B1	LAN2_MDIP0
A2	I218_LAN1_MDIO_DN	B2	LAN2_MDIN0
A3	I218_LAN1_MDI1_DP	B3	LAN2_MDIP1
A4	I218_LAN1_MDI1_DN	B4	LAN2_MDIN1
A7	I218_LAN1_MDI2_DP	B7	LAN2_MDIP2
A8	I218_LAN1_MDI2_DN	B8	LAN2_MDIN2
A9	I218_LAN1_MDI3_DP	B9	LAN2_MDIP3
A10	I218_LAN1_MDI3_DN	B10	LAN2_MDIN3

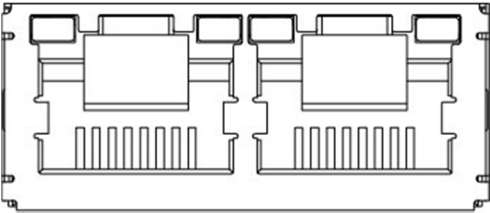

**CN20: USB 2.0**

PIN	DEFINITION
1	5V
2	USB1-
3	USB1+
4	GND
5	GND
6	5V
7	USB2-
8	USB2+
9	GND
10	GND

**CN21: USB 2.0**

PIN	DEFINITION
1	5V
2	USB1-
3	USB1+
4	GND
5	GND
6	5V
7	USB2-
8	USB2+
9	GND
10	GND

**CN8: USB3.0 \*2**

LOWER USB		UPPER USB	
PIN	DEFINITION	PIN	DEFINITION
1	USB_VCC0	10	USB_VCC1
2	USBD2-	11	USBD3-
3	USBD2+	12	USBD3+
4	GND	13	GND
5	USB_SSRX1N_C	14	USB_SSRX2N_C
6	USB_SSRX1P_C	15	USB_SSRX2P_C
7	GND	16	GND
8	USB3TN1	17	USB3TN2
9	USB3TP1	18	USB3TP2

**CN9: USB3.0 \*2**

LOWER USB		UPPER USB	
PIN	DEFINITION	PIN	DEFINITION
1	USB_VCC2	10	USB_VCC3
2	USBD0-	11	USBD1-
3	USBD0+	12	USBD1+
4	GND	13	GND
5	USB_SSRX3N_C	14	USB_SSRX4N_C
6	USB_SSRX3P_C	15	USB_SSRX4P_C
7	GND	16	GND
8	USB3TN3	17	USB3TN4
9	USB3TP3	18	USB3TP4

### CN6: Audio Jacks Connector (MIC)

PIN	DEFINITION
5	MIC_L
4	GND
3	NC
2	MIC1_R
1	GND

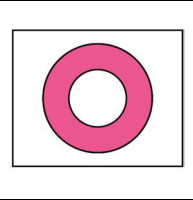

### CN7: Audio Jacks Connector (Line-Out)

PIN	DEFINITION
5	FRONT_L
4	GND
3	NC
2	FRONT_R
1	GND

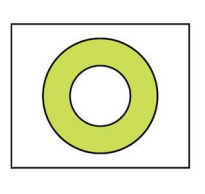

### CN22: DC Adapter Power Input

PIN	DEFINITION
1	+VIN
2	+VIN
3	GND
4	GND

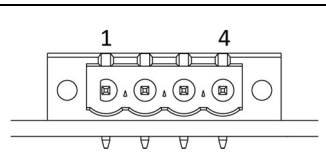

### DC\_JACK1: DC-IN

PIN	DEFINITION	PIN	DEFINITION
1	GND	2	GND
3	+VIN	4	+VIN

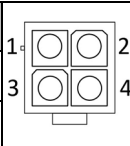

### CN10: LPC (Update BIOS)

PIN	DEFINITION
1	GND
2	INT_SERIRQ
3	3.3V
4	LPC_AD0
5	LPC_AD1
6	LPC_AD2
7	LPC_AD3
8	LPC_FRAME#
9	CHIP_PLTRST#
10	CLK

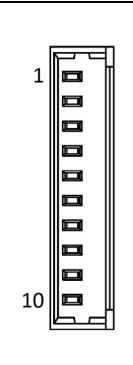

### DP1: DISPLAY PORT

PIN	DEFINITION	PIN	DEFINITION
1	DPC_LANEP0	2	GND
3	DPC_LANEN0	4	DPC_LANEP1
5	GND	6	DPC_LANEN1
7	DPC_LANEP2	8	GND
9	DPC_LANEN2	10	DPC_LANEP3
11	GND	12	DPC_LANEN3
13	DDIC_DDC_AUX_SEL	14	GND
15	DPC_AUXP	16	GND
17	DPC_AUXN	18	DPC_DET
19	GND	20	DPC_PWR





**DP2: DISPLAY PORT**

PIN	DEFINITION	PIN	DEFINITION
1	DPD_LANEP0	2	GND
3	DPD_LANEN0	4	DPD_LANEP1
5	GND	6	DPD_LANEN1
7	DPD_LANEP2	8	GND
9	DPD_LANEN2	10	DPD_LANEP3
11	GND	12	DPD_LANEN3
13	DDID_DDC_AUX_SEL	14	GND
15	DDID_AUXP	16	GND
17	DDID_AUXN	18	DPD_DET
19	GND	20	DPD_PWR

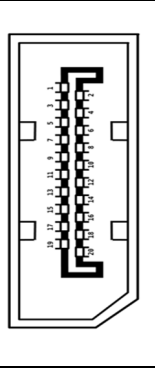

**SIM\_CARD1: SIM card socket**

PIN	DEFINITION
1	VCC
2	RESET
3	CLOCK
4	GND
5	VPP
6	DATA

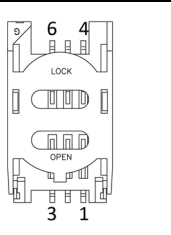

**DVI: DVI-D**

PIN	DEFINITION	PIN	DEFINITION
1	TMDS Data2-	13	NC
2	TMDS Data2+	14	+5V Power
3	GND	15	GND
4	NC	16	Hot Plug Detect
5	NC	17	TMDS Data0-
6	DDC Clock	18	TMDS Data0+
7	DDC Data	19	GND
8	Analog VSYNC	20	NC
9	TMDS Data1-	21	NC
10	TMDS Data1+	22	GND
11	GND	23	TMDS Clock+
12	NC	24	TMDS Clock-
C1	NC	C2	NC
C3	NC	C4	NC
C5	DVI_GND	C6	DVI_GND

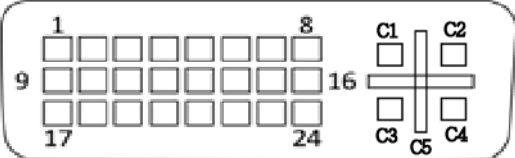

**COM1: RS232/422/485 with 5V/12V selectable**

PIN	DEFINITION	PIN	DEFINITION
1	DCD1#_OPTO	6	DSR1#_OPTO
2	RXD1_OPTO	7	RTS1#_OPTO
3	TDX1_OPTO	8	CTS1#_OPTO
4	DRT1#_OPTO	9	COM1P9SEL
5	GND	10	GND

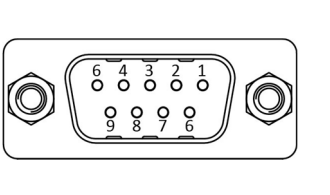

**JP4: COM1 5V/12V selection**

PIN	DEFINITION	PIN	DEFINITION
1	RI1#_OPTO	2	COM1P9SEL
3	5V	4	COM1P9SEL
5	12V	6	COM1P9SEL

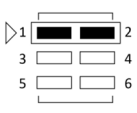

**JP5: COM2 5V/12V selection**

PIN	DEFINITION	PIN	DEFINITION
1	RI1#_OPTO	2	COM1P9SEL
3	5V	4	COM1P9SEL
5	12V	6	COM1P9SEL

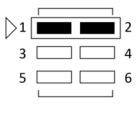

**COM2: RS232, with 5V/12V selectable**

PIN	DEFINITION
1	5VS
2	GND
3	COM2P9SEL
4	DTR-
5	CTS2-
6	TXD2-
7	RTS2-
8	RXD-
9	DSR-
10	DCD-



**COM3/4: RS232**

PIN	DEFINITION
1	5VS
2	GND
3	RI-
4	DTR-
5	CTS-
6	TXD-
7	RTS-
8	RXD-
9	DSR-
10	DCD-



## CON A1: CONNECTOR A TOP

PIN	DEFINITION	PIN	DEFINITION	PIN	DEFINITION	PIN	DEFINITION	PIN	DEFINITION	PIN	DEFINITION
1	USB_OC#6	2	BUF_PLT_RST-	53	3V3_DU	54	3V3_DU	105	GND	106	CLK_LPC_UART
3	3.3V	4	3.3V	55	3V3_DU	56	GND	107	NC	108	GND
5	USBD7+	6	USBD6+	57	ST_LAN1_MDIP0	58	NC	109	ST_LAN1_MDIP2	110	
7	USBD7-	8	USBD6-	59	ST_LAN1_MDIN0	60	NC	111	ST_LAN1_MDIN2	112	
9	GND	10	GND	61	GND	62	GND	113	GND	114	GND
11	PCIE_TXP5	12	PCIE_TXP7	63	ST_LAN2_MDIP0	64	NC	115	ST_LAN2_MDIP2	116	
13	PCIE_TXN5	14	PCIE_TXN7	65	ST_LAN2_MDIN0	66	NC	117	ST_LAN2_MDIN2	118	
15	GND	16	GND	67	GND	68	GND	119	GND	120	GND
17	PCIE_TXP6	18	PCIE_TXP8	69	ST_LAN1_MDIP1	70	NC	121	ST_LAN1_MDIP3	122	
19	PCIE_TXN6	20	PCIE_TXN8	71	ST_LAN1_MDIN1	72	NC	123	ST_LAN1_MDIN3	124	
21	GND	22	GND	73	GND	74	GND	125	GND	126	GND
23	PCIE_RXP5	24	PCIE_RXP7	75	ST_LAN2_MDIP1	76	NC	127	ST_LAN2_MDIP3	128	ST_LAN2_MDIP3
25	PCIE_RXN5	26	PCIE_RXN7	77	ST_LAN2_MDIN1	78	NC	129	ST_LAN2_MDIN3	130	ST_LAN2_MDIN3
27	GND	28	GND	79	ST_LAN2_ACT#	80	ST_LAN1_ACT#	131	PE_PRSNT1_A-	132	PE_PRSNT0_A
29	PCIE_RXP6	30	PCIE_RXP8	81	SATATXP5	82	SATATXP4	133	SATSRXP5	134	SATARXP5
31	PCIE_RXN6	32	PCIE_RXN8	83	SATATXN5	84	SATATXN4	135	SATSRXN5	136	SATARXN5
33	GND	34	GND	85	GND	86	GND	137	GND	138	GND
35	PEX5_PCIE_CLK	36	PEX7_PCIE_CLK	87	USBD9+	88	USBD11+	139	NC	140	
37	PEX5_PCIE_CLK#	38	PEX7_PCIE_CLK#	89	USBD9-	90	USBD11-	141	NC	142	
39	5V_DU	40	5V_DU	91	GND	92	GND	143	GND	144	GND
41	PEX6_PCIE_CLK	42	PEX8_PCIE_CLK	93	NC	94	USBD10+	145	LPC_AD0	146	LPC_LDRO0
43	PEX6_PCIE_CLK#	44	PEX8_PCIE_CLK#	95	NC	96	USBD10-	147	LPC_AD1	148	INT_SERIRQ
45	GND	46	5VS	97	GND	98	GND	149	GND	150	GND
47	SMB_DATA_MAIN	48	NC	99	ETH_1_CTREF	100	ETH_0_CTREF	151	LPC_AD2	152	LPC_FRAME
49	SMB_CLK_MAIN	50	NC	101	SPI_MISO_AA	102	SPI_CE0#_F	153	LPC_AD3	154	VRTC
51	SMBALERT#	52	BUS_PS_ON#	103	SPI_SI_F	104	SPI_CE1#_F	155	FUSB_1RTS-	156	FUSB_ORTS

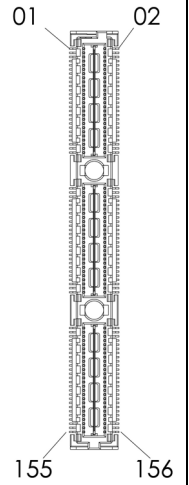

### FPE1: StackPC FPE Top Connector

PIN	DEFINITION	PIN	DEFINITION	PIN	DEFINITION	PIN	DEFINITION	PIN	DEFINITION
1	NC	2	NC	3	NC	4	NC	5	NC
11	GND	12	NC	13	GND	14	NC	15	GND
21	NC	22	NC	23	NC	24	GND	25	NC
31	NC	32	NC	33	NC	34	NC	35	NC
41	GND	42	NC	43	GND	44	NC	45	GND
51	NC	52	GND	53	NC	54	GND	55	NC
61	NC	62	NC	63	NC	64	NC	65	NC
71	GND	72	NC	73	GND	74	NC	75	GND
81	PEG_TXP0	82	NC	83	PEG_TXP2	84	GND	85	PEG_TXP4
91	PEG_TXN0	92	PEG_TXP1	93	PEG_TXN2	94	PEG_TXP3	95	PEG_TXN4
101	GND	102	PEG_TXN1	103	GND	104	PEG_TXN3	105	GND
111	PEG_RXP_0	112	GND	113	PEG_RXP_2	114	GND	115	PEG_RXP_4
121	PEG_RXN_0	122	PEG_RXP_1	123	PEG_RXN_2	124	PEG_RXP_3	125	PEG_RXN_4
131	GND	132	PEG_RXN_1	133	GND	134	PEG_RXN_3	135	GND
141	PEG_TXP8	142	GND	143	PEG_TXP10	144	GND	145	PEG_TXP12
151	PEG_TXN8	152	PEG_TXP9	153	PEG_TXN10	154	PEG_TXP11	155	PEG_TXN12
161	GND	162	PEG_TXN9	163	GND	164	PEG_TXN11	165	GND
171	PEG_RXP_8	172	GND	173	PEG_RXP_10	174	GND	175	PEG_RXP_12
181	PEG_RXN_8	182	PEG_RXP_9	183	PEG_RXN_10	184	PEG_RXP_11	185	PEG_RXN_12
191	GND	192	PEG_RXN_9	193	GND	194	PEG_RXN_11	195	GND
PIN	NAME	PIN	NAME	PIN	NAME	PIN	NAME	PIN	NAME
6	NC	7	NC	8	NC	9	NC	10	NC
16	NC	17	GND	18	NC	19	NC	20	NC
26	GND	27	NC	28	GND	29	NC	30	NC
36	NC	37	NC	38	NC	39	NC	40	NC
46	NC	47	GND	48	NC	49	GND	50	NC
56	GND	57	NC	58	GND	59	NC	60	NC
66	NC	67	NC	68	NC	69	SPKR	70	NC
76	NC	77	GND	78	NC	79	GND	80	NC
86	GND	87	PEG_TXP6	88	GND	89	NC	90	CFG5
96	PEG_TXP5	97	PEG_TXN6	98	PEG_TXP7	99	NC	100	CFG6
106	PEG_TXN5	107	GND	108	PEG_TXN7	109	GND	110	BUF_PLT_RST-
116	GND	117	PEG_RXP_6	118	GND	119	PEG_A_CLK_P	120	GND
126	PEG_RXP_5	127	PEG_RXN_6	128	PEG_RXP_7	129	PEG_A_CLK_N	130	3V3_DU
136	PEG_RXN_5	137	GND	138	PEG_RXN_7	139	GND	140	3V3_DU
146	GND	147	PEG_TXP14	148	GND	149	PEG_B_CLK_P	150	GND
156	PEG_TXP13	157	PEG_TXN14	158	PEG_TXP15	159	PEG_B_CLK_N	160	GND
166	PEG_TXN13	167	GND	168	PEG_TXN15	169	GND	170	NC
176	GND	177	PEG_RXP_14	178	GND	179	NC	180	12V
186	PEG_RXP_13	187	PEG_RXN_14	188	PEG_RXP_15	189	NC	190	12V
196	PEG_RXN_13	197	GND	198	PEG_RXN_15	199	NC	200	12V

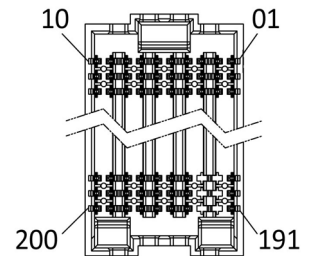

**LED1: LAN1 LED STATUS**

LED1	Light	Dark	Flash
RED	1000M	100M	NA
GREEN	LINK	UNLINK	ACTIVITY

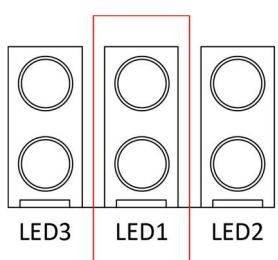

**LED2: LAN2 LED STATUS**

LED2	Light	Dark	Flash
RED	1000M	100M	NA
GREEN	Link	Un-link	Activity

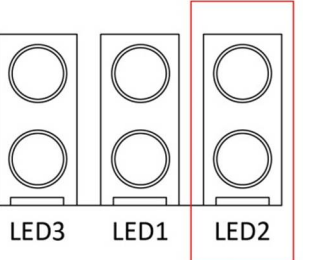

**LED3: POWER/HDD LED**

LED2	Light	Dark	Flash
RED	NA	HDD un-access	HDD access
GREEN	Power On	Power Off	NA

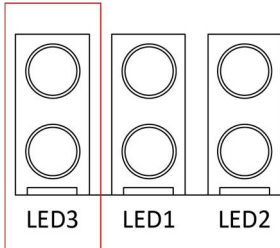

**SW1: POWER BUTTON**

PIN	DEFINITION
ON	NO LIGHT
OFF	BLUE LIGHT

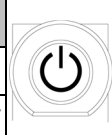

**FP1: Front Panel**

PIN	DEFINITION	PIN	DEFINITION
1	HDLED+	2	PLED+
3	HDLED-	4	GND
5	GND	6	EC_PWR_BTN
7	EXT_RESET#	8	GND
9	NC	10	NC

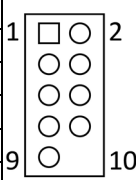

## FP2: LAN LED

PIN	DEFINITION	PIN	DEFINITION
1	3V3M	2	3V3M
3	LAN_LED_LNK#_ACT	4	LAN2_ACT#
5	LAN_LED_LNK_1000#	6	LAN2_LED_1000-
7	LAN_LED_LNK_100#	8	LAN2_LED_100-

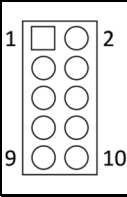

### Plug LED cable to FP2 pin header

Active LED: plug 1-3 pin

Single 1000M LED: plug 1-5 pin

Single 100M LED: plug 1-7 pin

Dual 1000M LED: plug 5-7 pin

## Chapter 3: Getting Started

### 3.1 Installing System Memory

The OXY5740A supports 1 x DDR4 XR-DIMM up to 16GB (Top Side), 1 x DDR4 SODIMM up to 16GB



**Disconnect all power supplies to the board before installing a memory module to prevent damage to the board and memory module.**

To install a memory module:

1. Located the memory module slots on the motherboard.

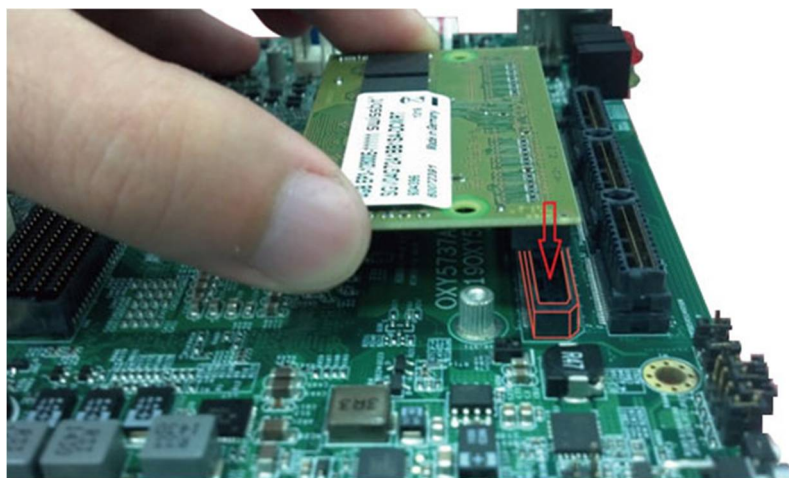

2. Align the memory module with the socket to make sure the notch aligns with the slot key on the socket.

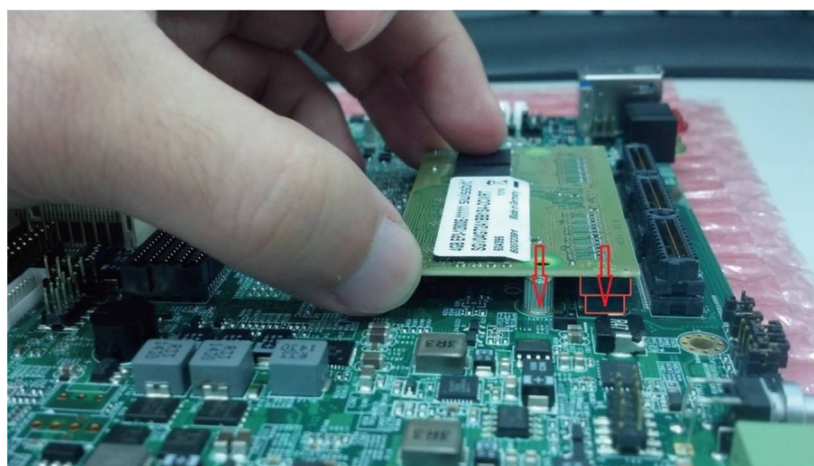

3. Insert the module firmly into the desired slot until the slot lock and secure the memory module.

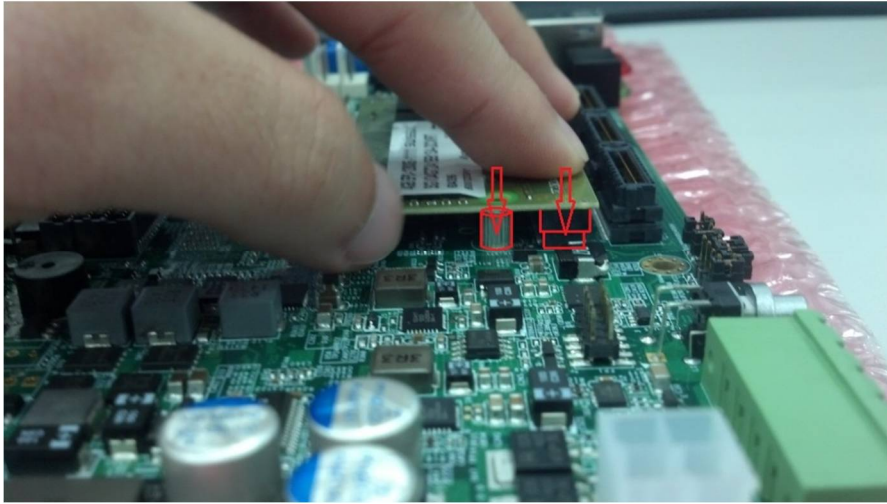

4. After insert the module to the desire slot, drive screws tighten with memory module's crew hole and bolt on PCB board.





## Chapter 4: AMI BIOS UTILITY

This chapter provides users with detailed descriptions on how to set up a basic system configuration through the AMI BIOS setup utility.

### 4.1 Starting

To enter the setup screens, perform the following steps:

- Turn on the computer and press the <Del> key immediately.
- After the <Del> key is pressed, the main BIOS setup menu displays. Other setup screens can be accessed from the main BIOS setup menu, such as the Chipset and Power menus.

### 4.2 Navigation Keys

The BIOS setup/utility uses a key-based navigation system called hot keys. Most of the BIOS setup utility hot keys can be used at any time during the setup navigation process.

Some of the hot keys are <F1>, <F10>, <Enter>, <ESC>, and <Arrow> keys.



**Some of the navigation keys may differ from one screen to another.**

Left/Right	The Left and Right <Arrow> keys moves the cursor to select a menu.
Up/Down	The Up and Down <Arrow> keys moves the cursor to select a setup screen or sub-screen.
+– Plus/Minus	The Plus and Minus <Arrow> keys changes the field value of a particular setup setting.
Tab	The <Tab> key selects the setup fields.
F1	The <F1> key displays the General Help screen.
F10	The <F10> key saves any changes made and exits the BIOS setup utility.
Esc	The <Esc> key discards any changes made and exits the BIOS setup utility.
Enter	The <Enter> key displays a sub-screen or changes a selected or highlighted option in each menu.

### 4.3 Main Menu

The Main menu is the screen that first displays when BIOS Setup is entered, unless an error has occurred.

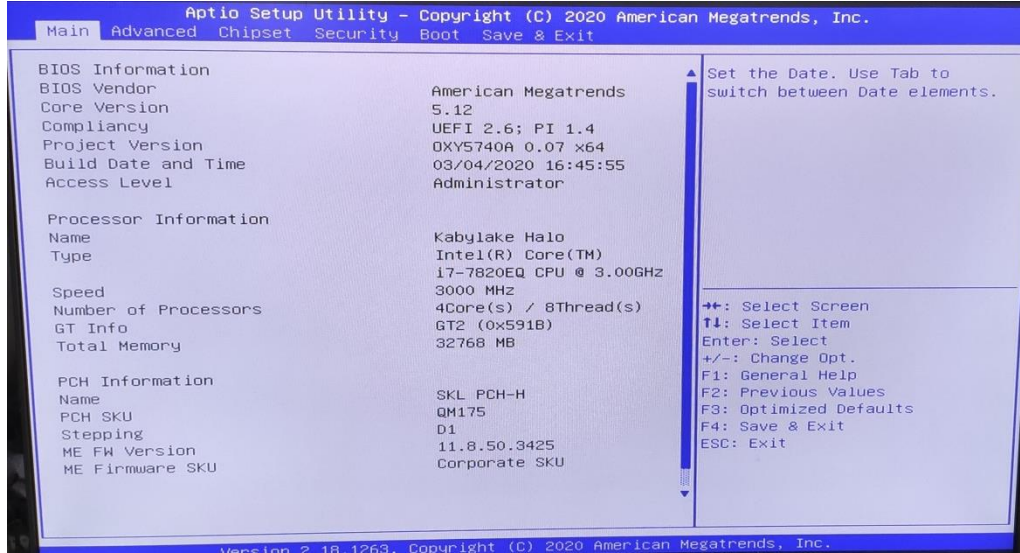

### System Date

Use this function to change the system date.

Select System Date using the Up and Down <Arrow> keys. Enter the new values through the keyboard. Press the Left and Right <Arrow> keys to move between fields.

The date setting must be entered in MM/DD/YY format.

### System Time

Use this function to change the system time.

Select System Time using the Up and Down <Arrow> keys. Enter the new values through the keyboard. Press the Left and Right <Arrow> keys to move between fields.

The time setting is entered in HH:MM:SS format.

**Note:** The time is in 24-hour format. For example, 5:30 A.M. appears as 05:30:00, and 5:30 P.M. as 17:30:00.

### Access Level

Display the access level of the current user in the BIOS.

### 4.4 Advanced Menu

The Advanced Menu allows you to configure your system for basic operation. Some entries are defaults required by the system board, while others, if enabled, will improve the performance of your system or let you set some features according to your preference. **Setting incorrect field values may cause the system to malfunction.**

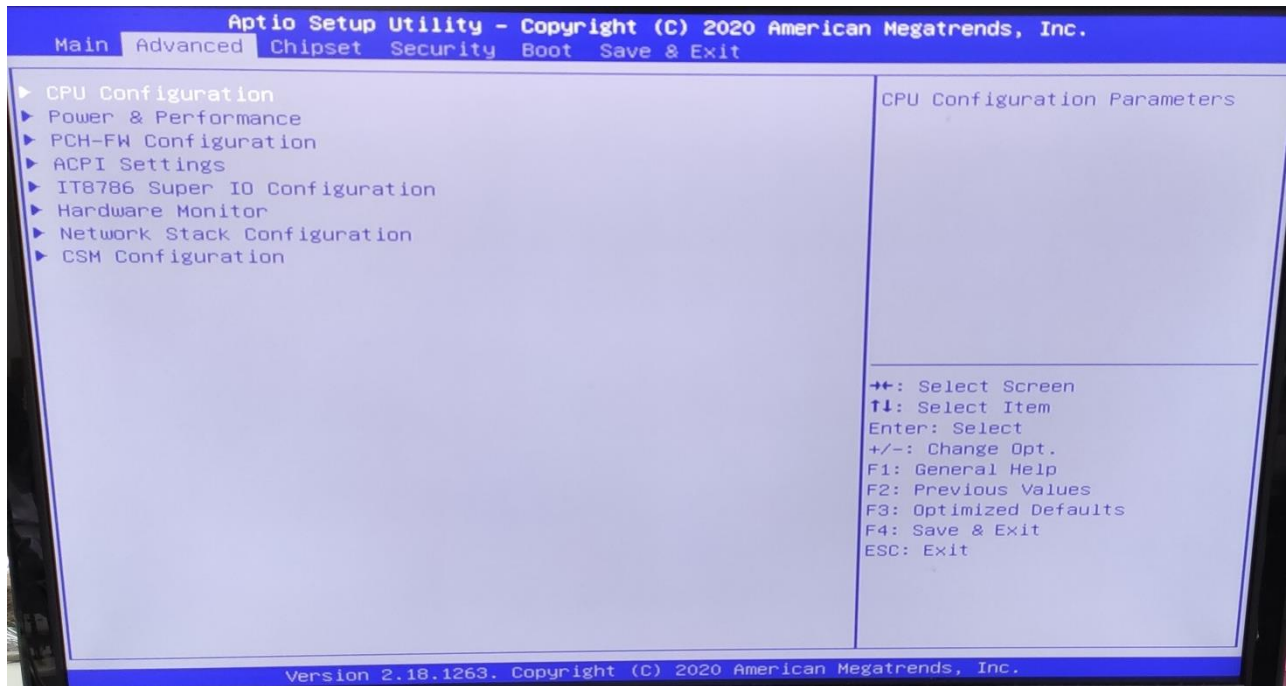

#### 4.4.1 CPU Configuration

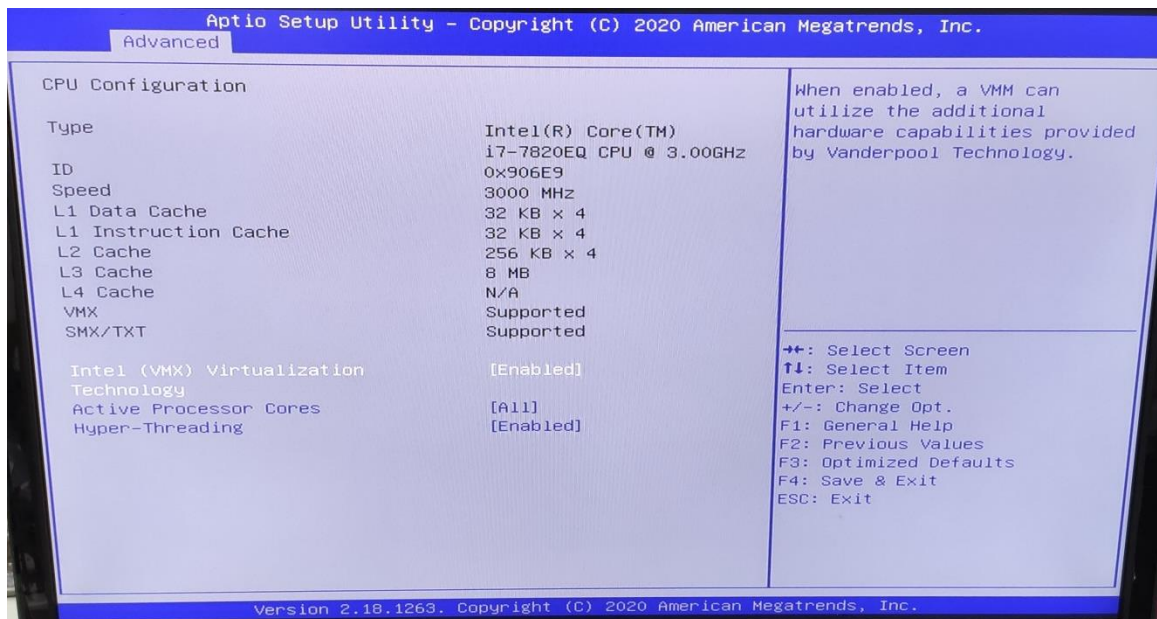

#### 4.4.2 Power & Performance

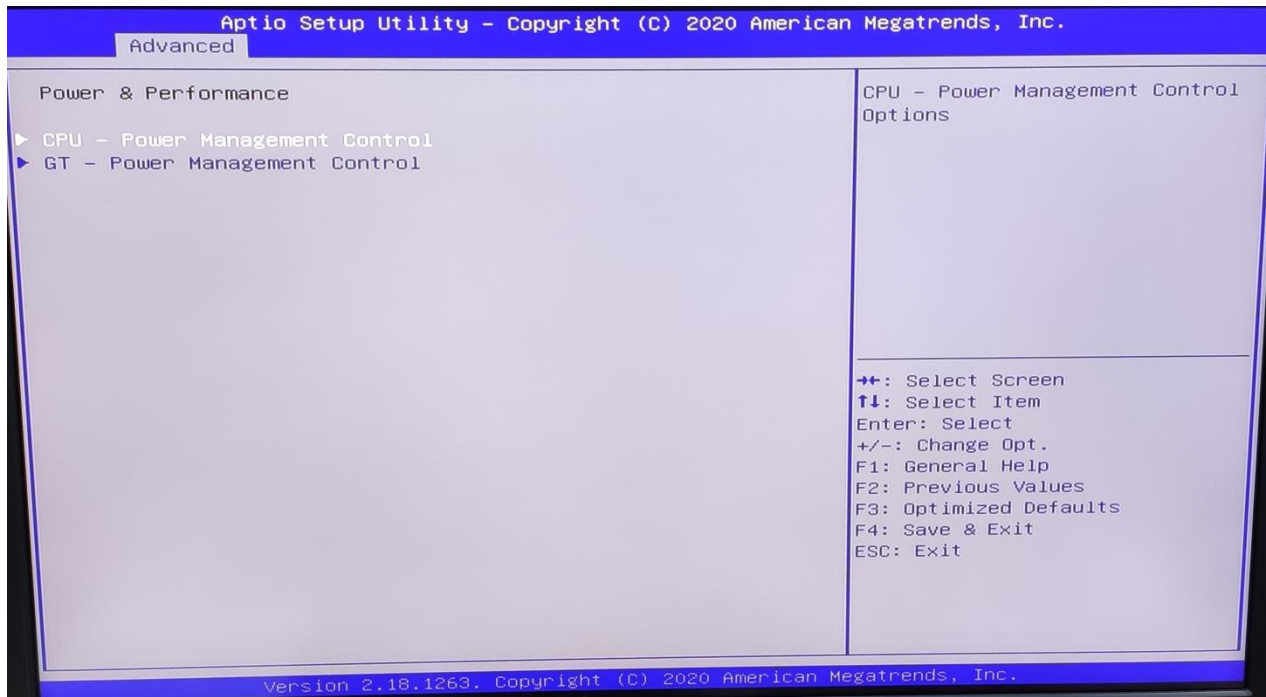

#### 4.4.3 PCH-FW Configuration

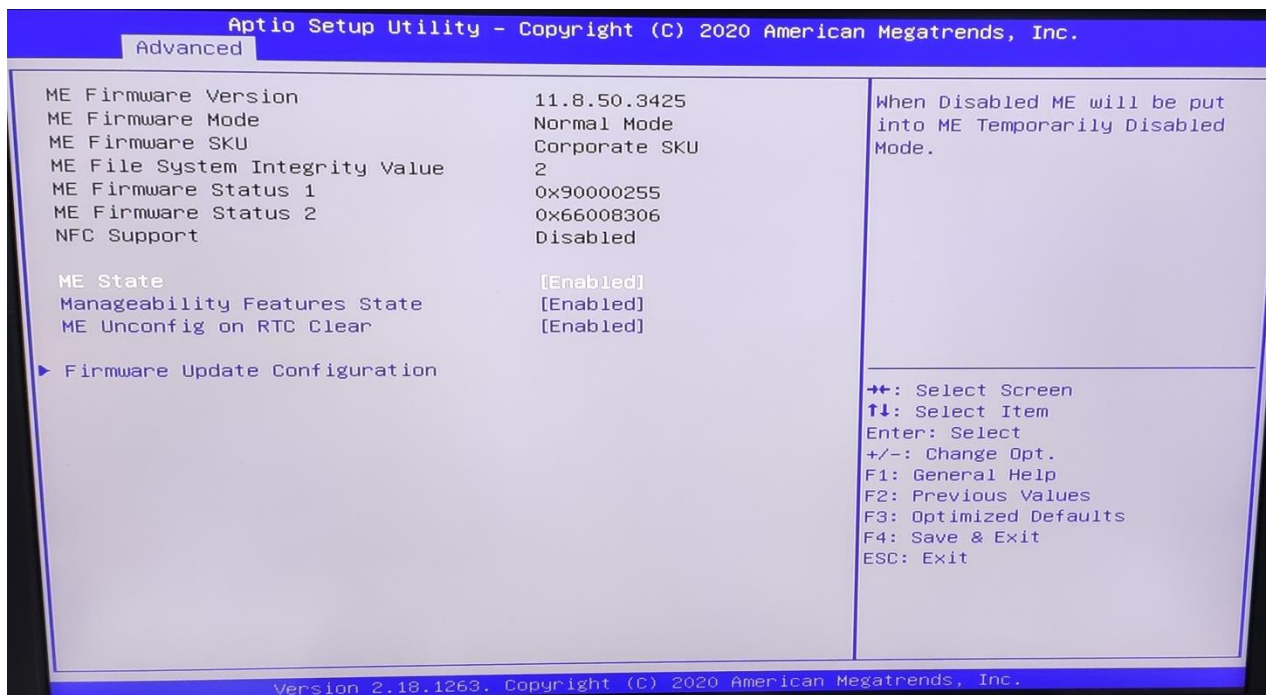

#### 4.4.4 ACPI Setting

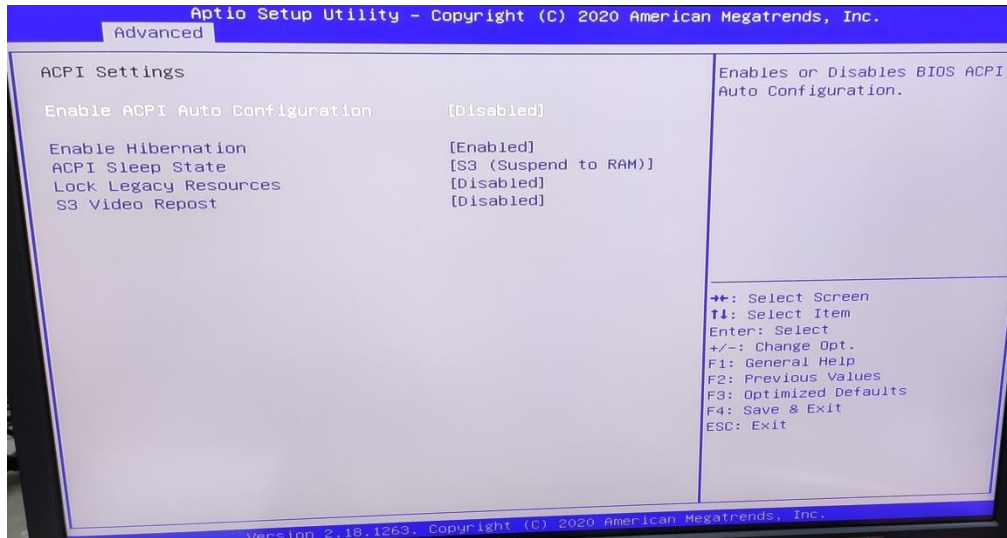

#### 4.4.5 IT8786 Super IO Configuration

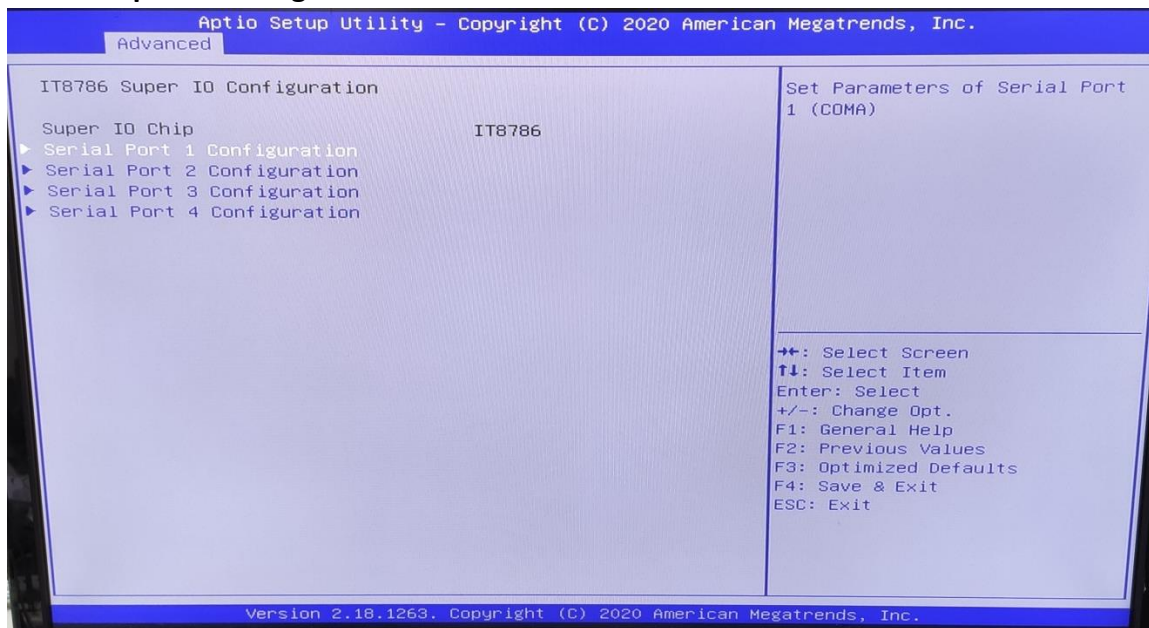

User can choose a mode (RS232/RS422/RS485) on each serial port.

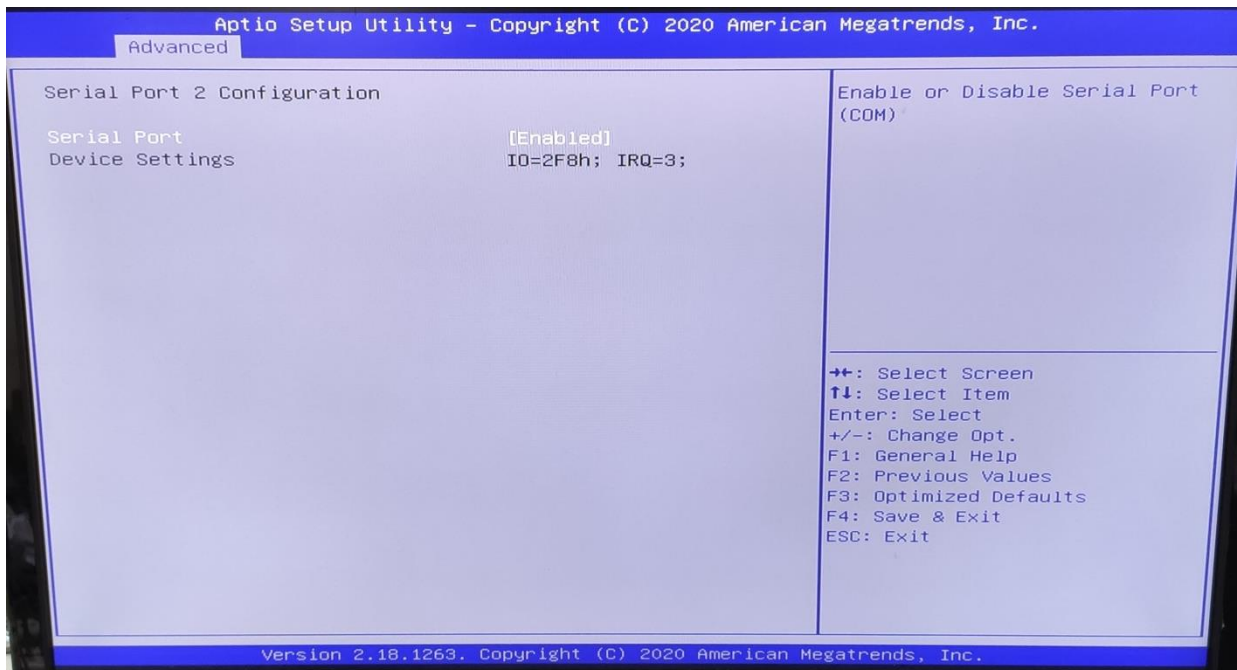
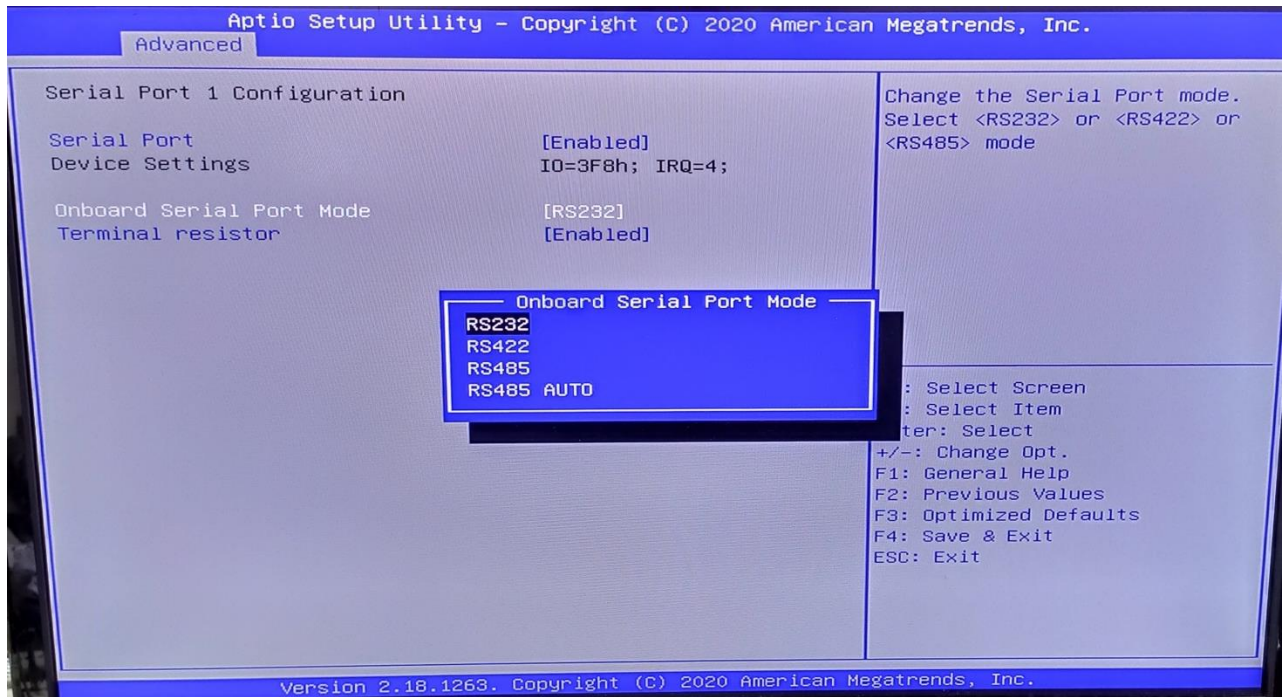

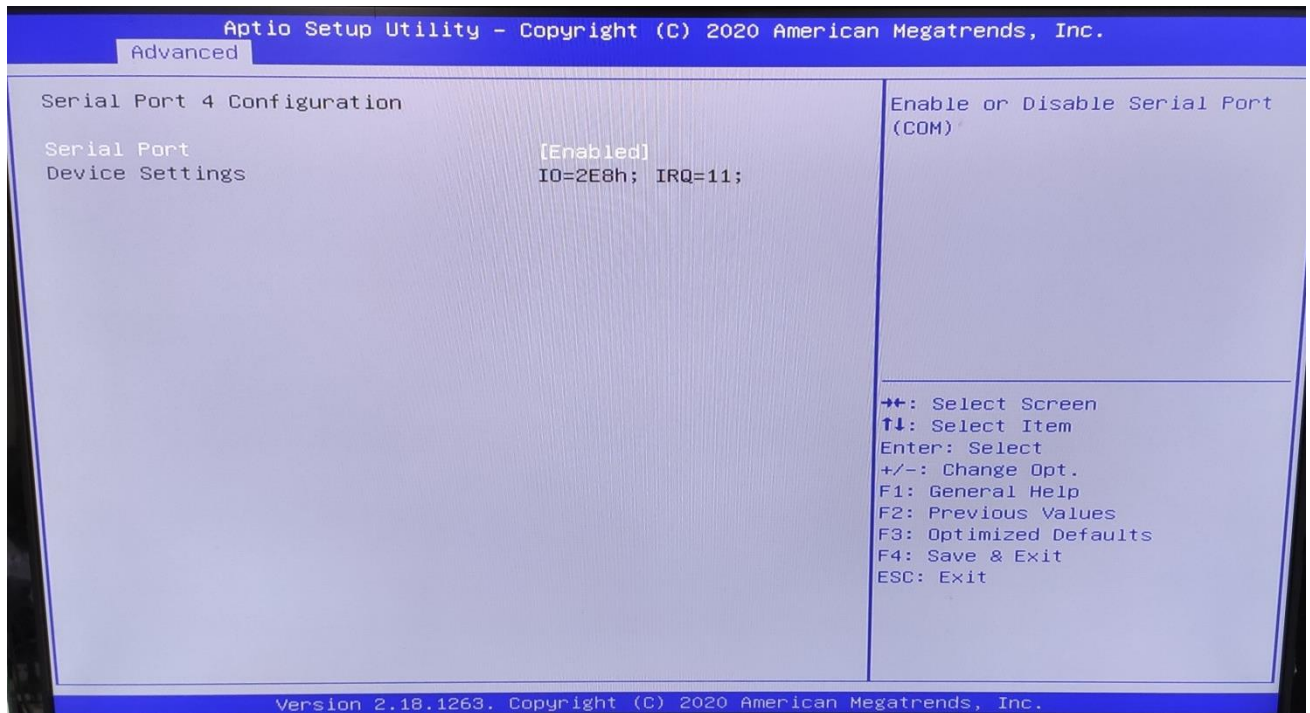
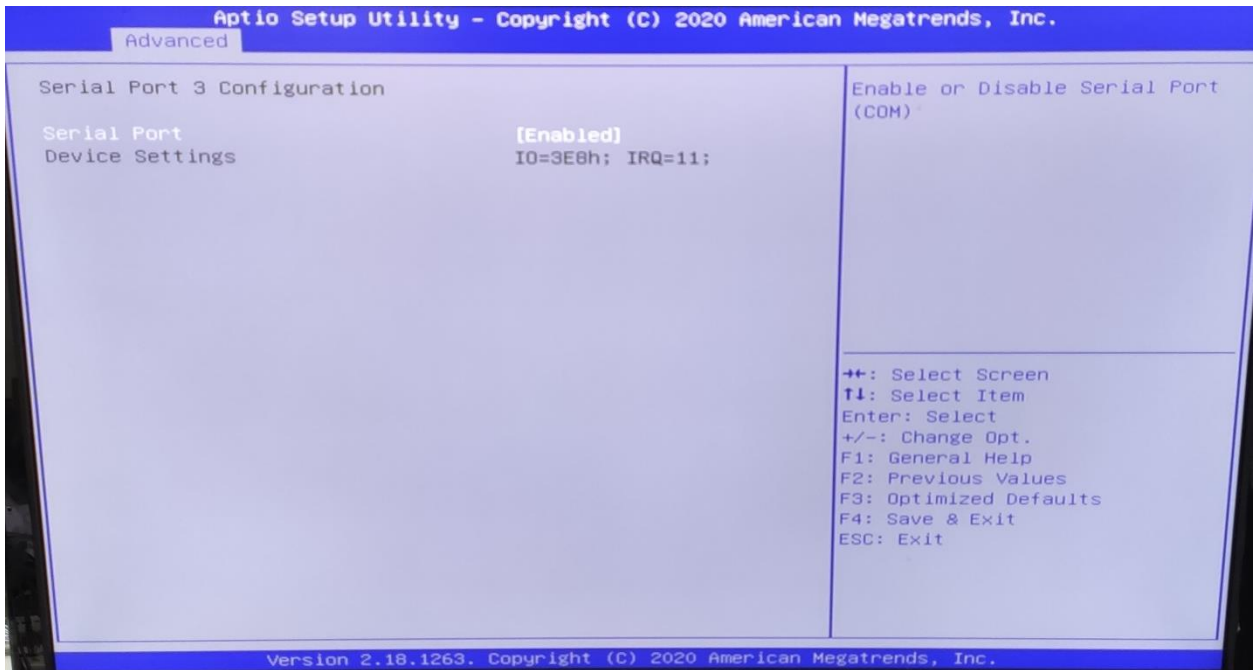

#### 4.4.6 Hardware Monitor

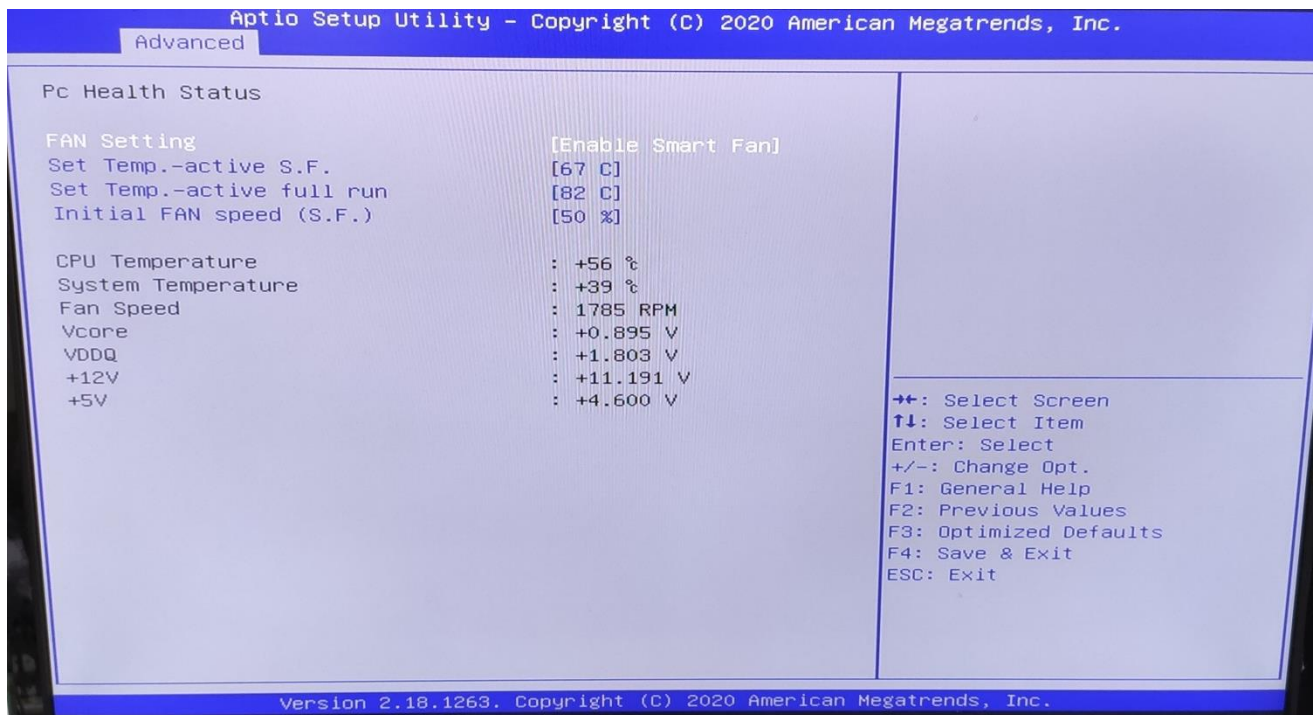

#### 4.4.7 CSM Configuration

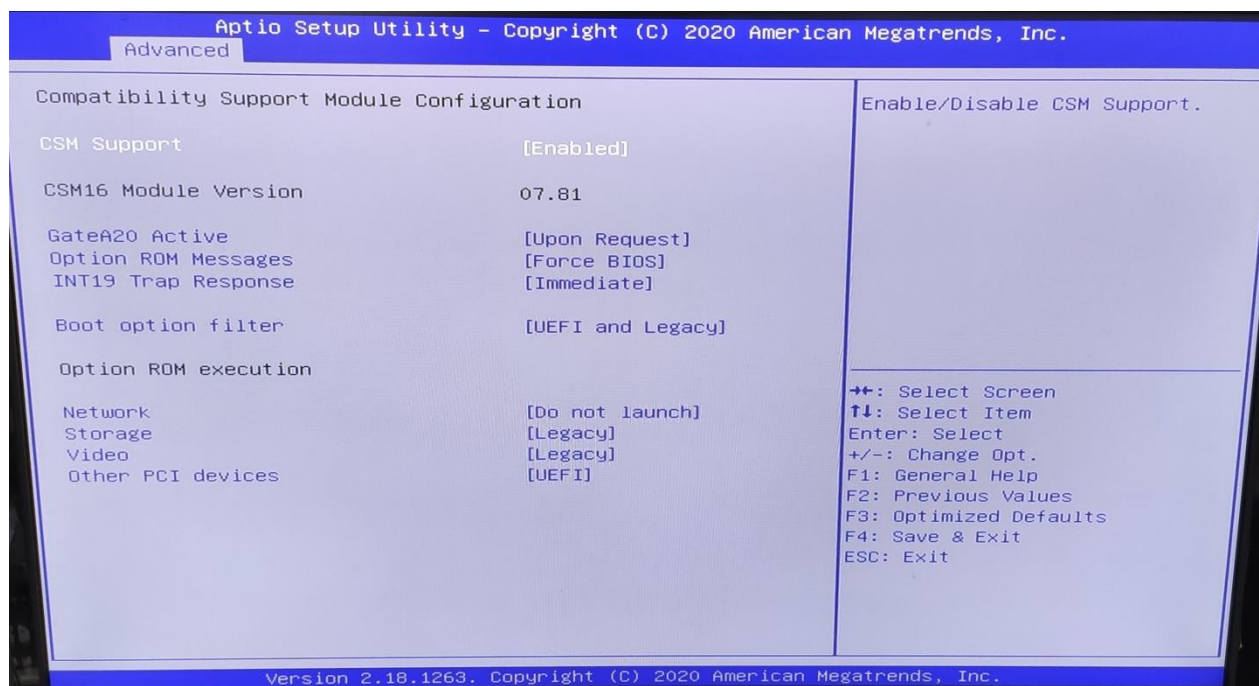

#### 4.5 Chipset



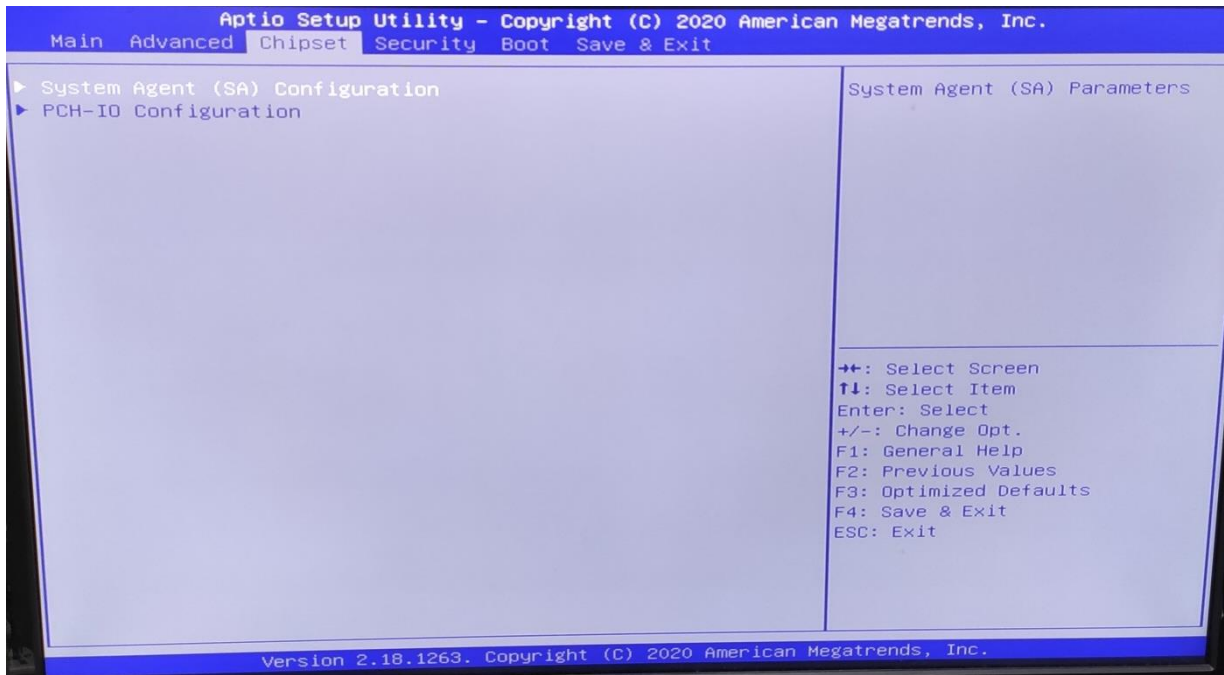

#### 4.5.1 SA Configuration

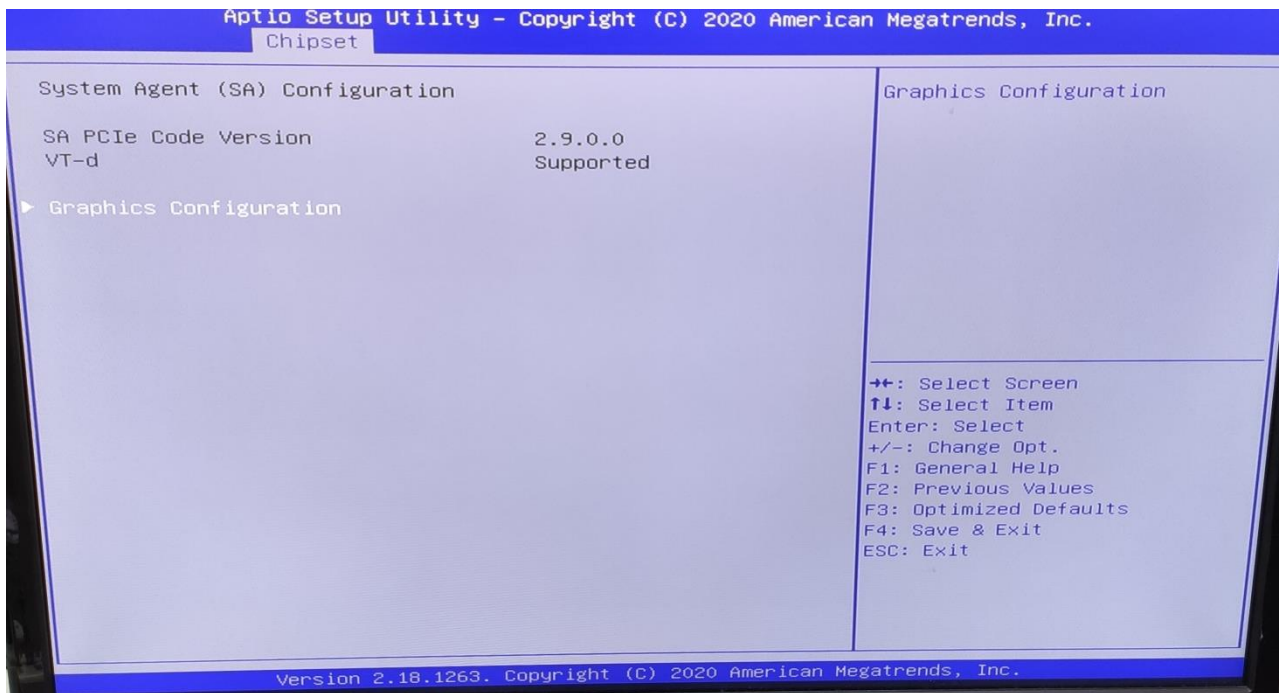

#### 4.5.1.1 Graphics Configuration

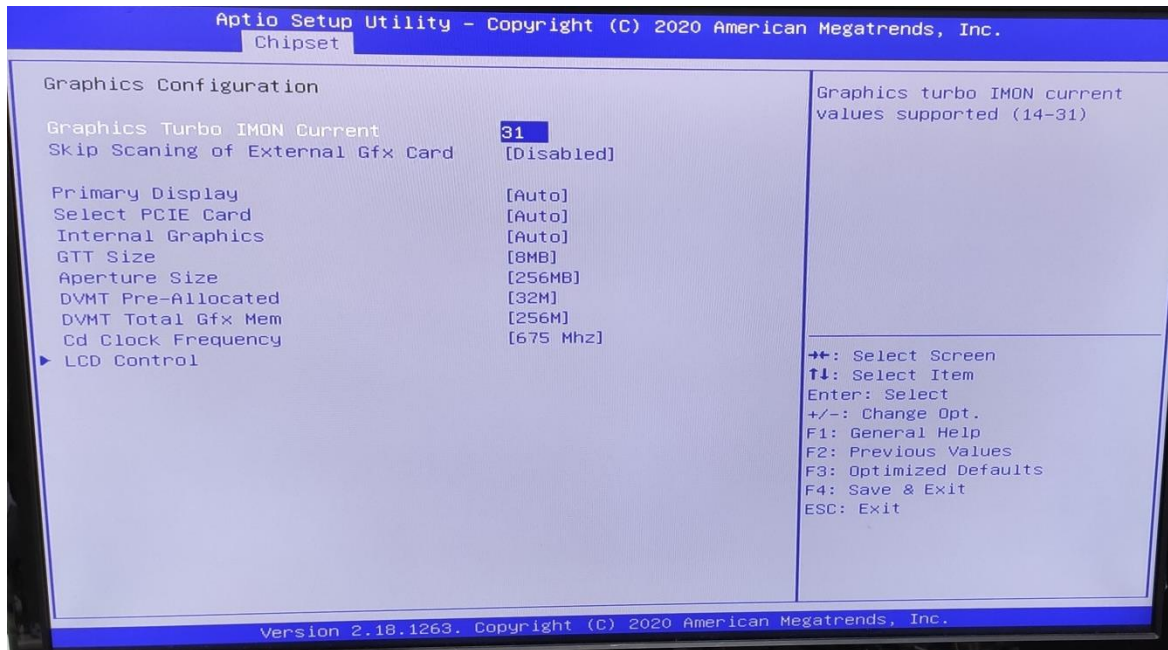

#### 4.5.1.2 LCD Control

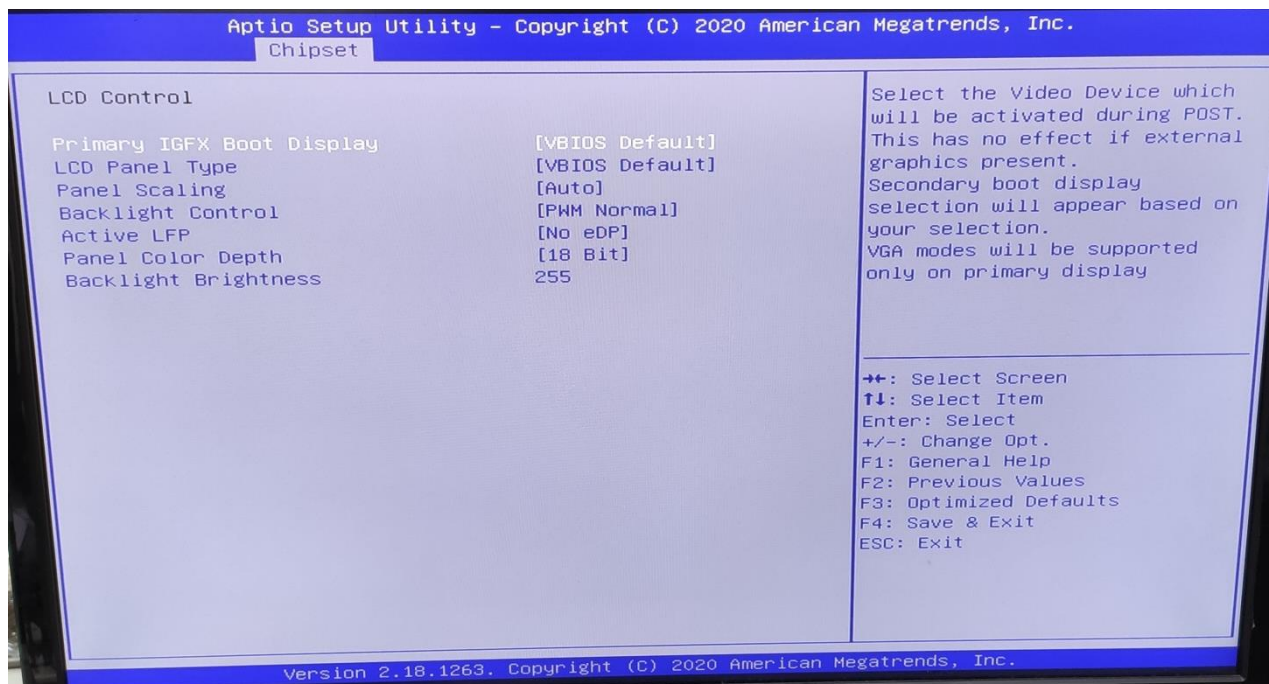

**Primary IGFX Boot Display:** Select the Video Device which will be activated during POST. This has no effect if external graphics present. Secondary boot display selection will appear based on your selection. VGA modes will be supported only on primary display.

**LCD Panel Type:** Select LCD panel used by Internal Graphics Device by selecting the appropriate setup item.

**SDVO-LFP Panel Type:** Select SDVO panel used by Internal Graphics Device by selecting the appropriate setup item.

**Panel Scaling:** Select the LCD panel scaling option used by the Internal Graphics Device.

**Backlight control:** backlight control setting

**Panel Color Depth:** select the LFP panel color depth.

#### 4.5.2 PCH-IO Configuration

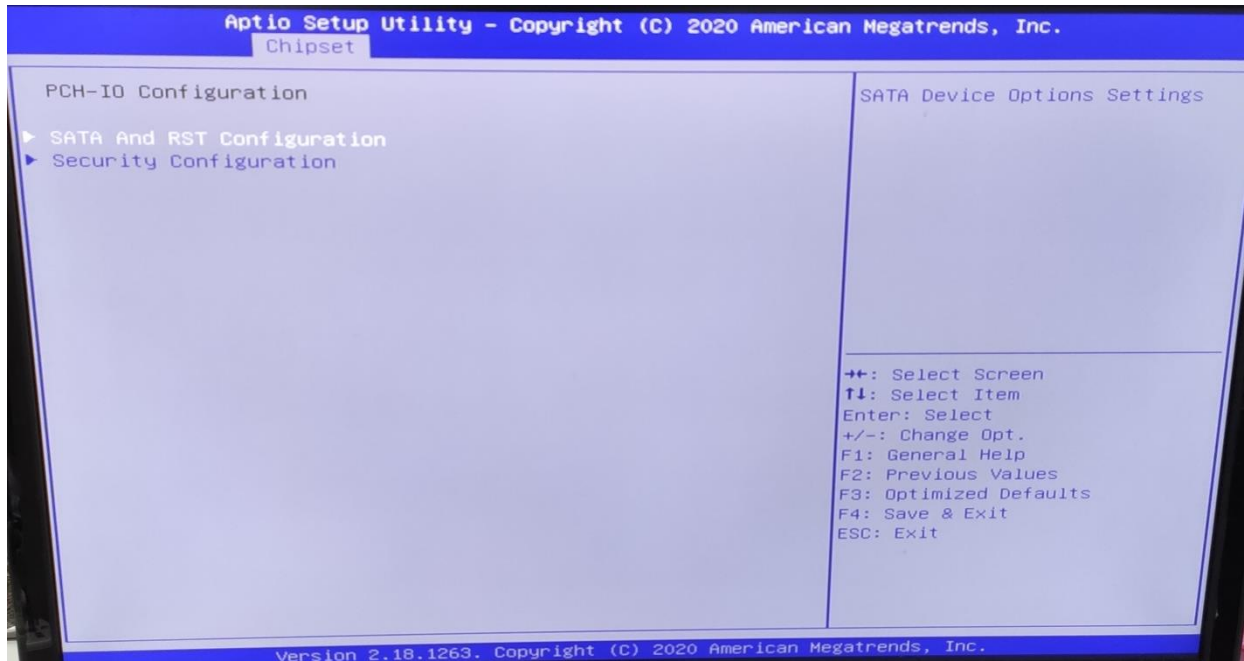

#### 4.6 Security

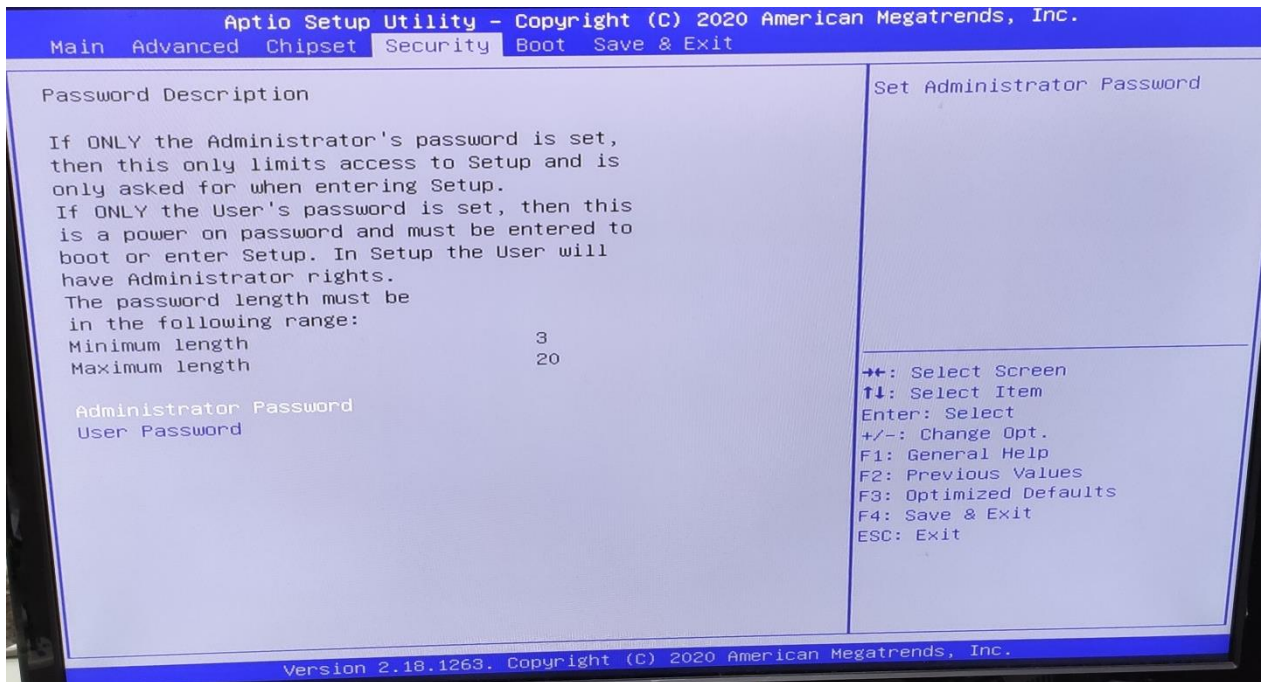

#### 4.7 Boot

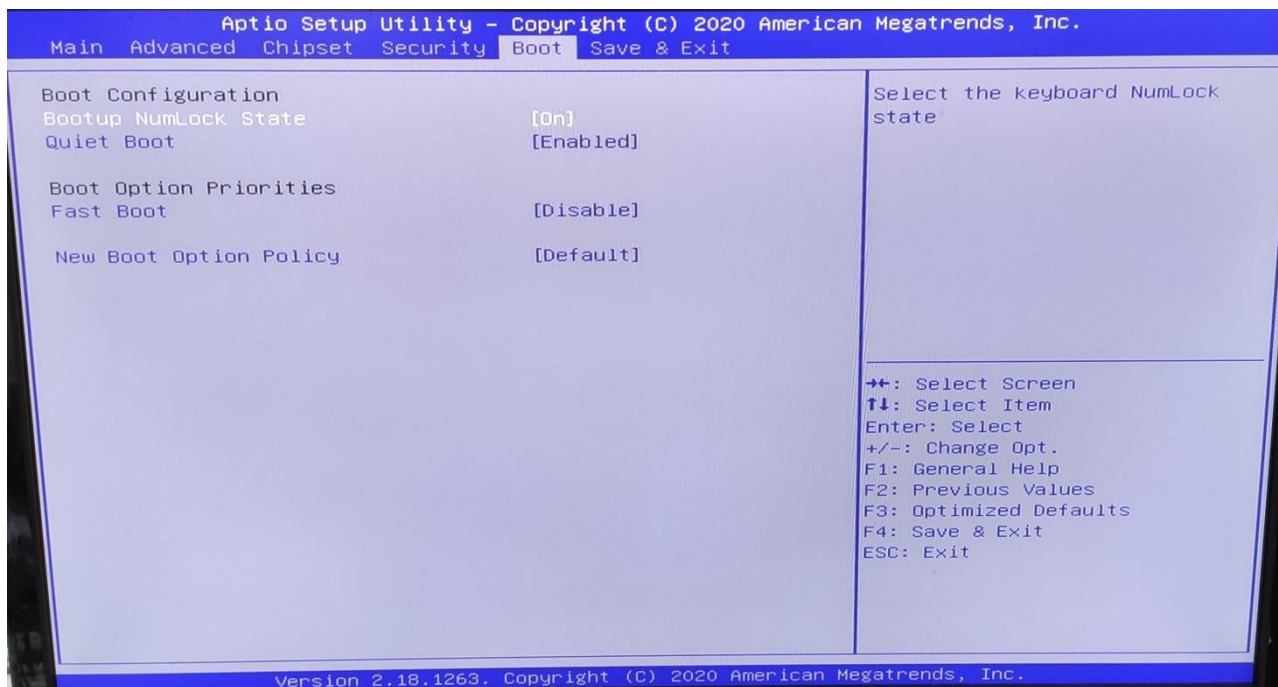

**Bootup NumLock State:** Select the keyboard NumLock state.

**Quiet Boot:** Enables or disables Quiet Boot option.

**Fast Boot:** Enables or disables boot with initialization of a minimal set of devices required to launch active boot option. Has no effect for BBS boot options.

**Boot option priorities**

**Boot Option #1:** Sets the system boot order.

**4.8 Save & Exit**

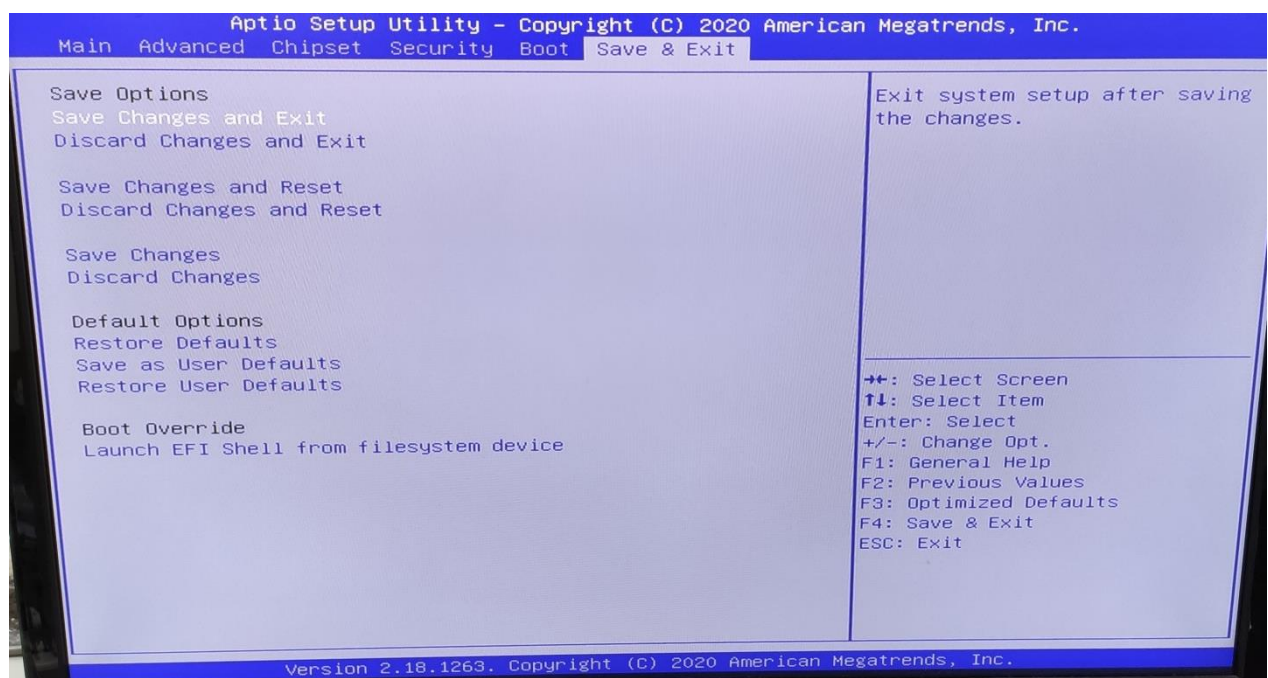

This screen provides functions for handling changes made to the BIOS settings and the exiting of the Setup program.

**Save Changes and Exit**

Exit system setup after saving the changes.

**Discard Changes and Exit**

Exit system setup without saving any changes.

**Save Changes and Reset**

Reset the system after saving the changes.

**Discard Changes and Reset**

Reset system setup without saving any changes.

Save Options

**Save Changes:** Save Changes done so far to any of the setup options.

**Discard Changes:** Discard Changes done so far to any of the setup options.